



# LandMax

Suppliers Of Quality Agricultural Machinery

**21 Plummers Point Road, Tauranga**



## **Grapple with Rotator**

**ZD100**

## **Operator's Manual**

# TABLE OF CONTENTS

SECTION	DESCRIPTION	PAGE
1	Introduction .....	1
2	Safety.....	2
2.1	General Safety.....	3
2.2	Equipment Safety Guidelines .....	4
2.3	Safety Training.....	5
2.4	Safety Signs.....	5
2.5	Preparation .....	6
2.6	Operating Safety.....	7
2.7	Hydraulic Safety.....	8
2.8	Storage Safety .....	8
2.9	Transport Safety .....	9
2.10	Maintenance Safety .....	9
2.11	Employee Sign-Off Form .....	10
3	Safety Sign Locations .....	11
4	Operation .....	12
4.1	To the New Owner or Operator.....	12
4.2	Machine Components.....	13
4.3	Machine Break-In.....	14
4.4	Pre-Operation Checklist.....	14
4.5	Assembly .....	15
4.6	Equipment Matching .....	17
4.7	Controls .....	17
4.8	Attaching/Unhooking Tractor .....	18
4.9	Field Operation .....	21
4.10	Transporting.....	27
4.11	Storage .....	28
5	Service and Maintenance .....	29
5.1	Service.....	29
5.1.1	Fluids and Lubricants.....	29
5.1.2	Greasing .....	29
5.1.3	Servicing Intervals .....	30
5.1.4	Service Record .....	31
6	Troubleshooting .....	32
7	Specification .....	33
7.1	Mechanical.....	33
7.2	Hydraulic Fitting Torque .....	33
7.3	Bolt Torque.....	34
8	Index.....	35

## 2 SAFETY

### SAFETY ALERT SYMBOL

This Safety Alert symbol means **ATTENTION! BECOME ALERT! YOUR SAFETY IS INVOLVED!**

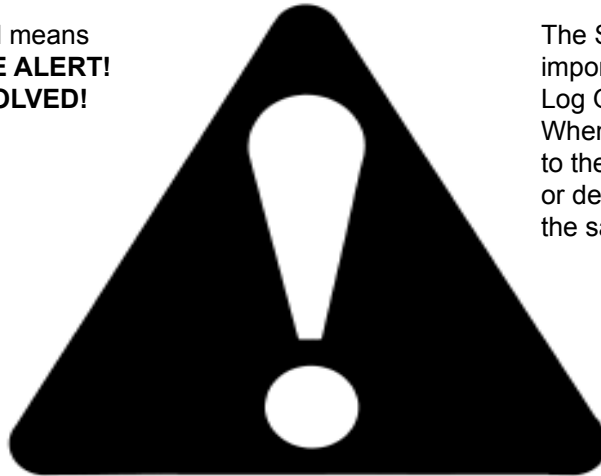

The Safety Alert symbol identifies important safety messages on the Log Grapple and in the manual. When you see this symbol, be alert to the possibility of personal injury or death. Follow the instructions in the safety message.

Why is SAFETY important to you?

#### 3 Big Reasons

**Accidents Disable and Kill**  
**Accidents Cost**  
**Accidents Can Be Avoided**

#### SIGNAL WORDS:

Note the use of the signal words **DANGER**, **WARNING** and **CAUTION** with the safety messages. The appropriate signal word for each message has been selected using the following guide-lines:

**DANGER** - Indicates an imminently hazardous situation that, if not avoided, will result in death or serious injury. This signal word is to be limited to the most extreme situations typically for machine components which, for functional purposes, cannot be guarded.

**WARNING** - Indicates a potentially hazardous situation that, if not avoided, could result in death or serious injury, and includes hazards that are exposed when guards are removed. It may also be used to alert against unsafe practices.

**CAUTION** - Indicates a potentially hazardous situation that, if not avoided, may result in minor or moderate injury. It may also be used to alert against unsafe practices.

# SAFETY

**YOU** are responsible for the **SAFE** operation and maintenance of your 3 Point Hitch Log Grapple. **YOU** must ensure that you and any-one else who is going to operate, maintain or work around the Log Grapple be familiar with the operating and maintenance procedures and related **SAFETY** information contained in this manual. This manual will take you step-by-step through your working day and alerts you to all good safety practices that should be adhered to while operating the Log Grapple.

Remember, **YOU** are the key to safety. Good safety practices not only protect you but also the people around you. Make these practices a working part of your safety program. Be certain that **EVERYONE** operating this equipment is familiar with the recommended operating and maintenance procedures and follows all the safety precautions. Most accidents can be prevented. Do not risk injury or death by ignoring good safety practices.

- Log Grapple owners must give operating instructions to operators or employees before allowing them to operate the machine, and at least annually.
- The most important safety feature on this equipment is a **SAFE** operator. It is the operator's responsibility to read and understand **ALL** Safety and Operating instructions in the manual and to follow these. Most accidents can be avoided.
- A person who has not read and understood all operating and safety instructions is not qualified to operate the machine. An untrained operator exposes himself and bystanders to possible serious injury or death.
- Do not modify the equipment in any way. Unauthorized modification may impair the function and/or safety and could affect the life of the equipment.
- Think **SAFETY!** Work **SAFELY!**

## 2.1 GENERAL SAFETY

1. Read and understand the Operator's Manual and all safety signs before operating, maintaining, adjusting or unplugging the Log Grapple.



2. Have a first-aid kit available for use should the need arise and know how to use it.

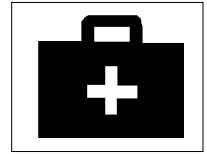

3. Have a fire extinguisher available for use should the need arise and know how to use it.

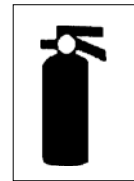

4. Do not allow riders.

5. Wear appropriate protective gear. This list includes but is not limited to:

- A hard hat
- Protective shoes with slip resistant soles
- Protective goggles, glasses or face shield
- Heavy gloves
- Protective clothing



6. Install and secure all guards before starting.

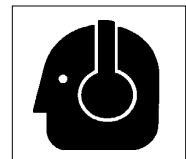

7. Wear suitable ear protection for prolonged exposure to excessive noise.

8. Place all controls in neutral, stop tractor engine, set park brake, remove ignition key and wait for all moving parts to stop before servicing, adjusting, repairing or unplugging.

9. Clear the area of people, especially small children, before starting.

10. Review safety related items annually with all personnel who will be operating or maintaining the Log Grapple.

# 1 INTRODUCTION

Safe, efficient and trouble free operation of your Log Grapple requires that you and anyone else who will be operating or maintaining the machine, read and understand the Safety, Operation, Maintenance and Trouble Shooting information contained within the Operator's Manual.



Keep this manual handy for frequent reference and to pass on to new operators or owners.

**OPERATOR ORIENTATION** - The directions left, right, front and rear, as mentioned throughout this manual, are as seen from the driver's seat and facing in the direction of travel.

## 2.2 EQUIPMENT SAFETY GUIDELINES

1. Safety of the operator and bystanders is one of the main concerns in designing and developing a machine. However, every year many accidents occur which could have been avoided by a few seconds of thought and a more careful approach to handling equipment. You, the operator, can avoid many accidents by observing the following precautions in this section. To avoid personal injury or death, study the following precautions and insist those working with you, or for you, follow them.
2. In order to provide a better view, certain photographs or illustrations in this manual may show an assembly with a safety shield removed. However, equipment should never be operated in this condition. Keep all shields in place. If shield removal becomes necessary for repairs, replace the shield prior to use.
3. Replace any safety sign or instruction sign that is not readable or is missing. Location of such safety signs is indicated in this manual.
4. Never use alcoholic beverages or drugs which can hinder alertness or coordination while operating this equipment. Consult your doctor about operating this machine while taking prescription medications.
5. **Under no circumstances should young children be allowed to work with this equipment. Do not allow persons to operate or assemble this unit until they have read this manual and have developed a thorough understanding of the safety precautions and of how it works.** Review the safety instructions with all users annually.
6. This equipment is dangerous to children and persons unfamiliar with its operation. The operator should be a responsible, properly trained and physically able person familiar with farm machinery and trained in this equipment's operations. If the elderly are assisting with work, their physical limitations need to be recognized and accommodated.
7. Use a tractor equipped with a Roll Over Protective Structure (ROPS) and a seat belt.
8. Never exceed the limits of a piece of machinery. If its ability to do a job, or to do so safely, is in question - **DON'T TRY IT.**
9. Do not modify the equipment in any way. Unauthorized modification result in serious injury or death and may impair the function and life of the equipment.
10. In addition to the design and configuration of this implement, including Safety Signs and Safety Equipment, hazard control and accident prevention are dependent upon the awareness, concern, prudence, and proper training of personnel involved in the operation, transport, maintenance, and storage of the machine. Refer also to Safety Messages and operation instruction in each of the appropriate sections of the Tractor and machine Manuals. Pay close attention to the Safety Signs affixed to the Tractor and the machine.

## 2.3 SAFETY TRAINING

1. Safety is a primary concern in the design and manufacture of our products. Unfortunately, our efforts to provide safe equipment can be wiped out by a single careless act of an operator or bystander.
2. In addition to the design and configuration of equipment, hazard control and accident prevention are dependent upon the awareness, concern, prudence and proper training of personnel involved in the operation, transport, maintenance and storage of this equipment.
3. It has been said, "The best safety feature is an informed, careful operator." We ask you to be that kind of an operator. It is the operator's responsibility to read and understand ALL Safety and Operating instructions in the manual and to follow these. Accidents can be avoided.
4. **Working with unfamiliar equipment can lead to careless injuries. Read this manual, and the manual for your tractor, before assembly or operating, to acquaint yourself with the machines. If this machine is used by any person other than yourself, or is loaned or rented, it is the machine owner's responsibility to make certain that the operator, prior to operating:**
  - a. **Reads and understands the operator's manuals.**
  - b. **Is instructed in safe and proper use.**
5. Know your controls and how to stop tractor engine and machine quickly in an emergency. Read this manual and the one provided with your tractor.
6. Train all new personnel and review instructions frequently with existing workers. Be certain only a properly trained and physically able person will operate the machinery. A person who has not read and understood all operating and safety instructions is not qualified to operate the machine. An untrained operator exposes himself and bystanders to possible serious injury or death. If the elderly are assisting with farm work, their physical limitations need to be recognized and accommodated.

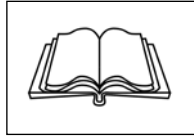

## 2.4 SAFETY SIGNS

1. Keep safety signs clean and legible at all times.
2. Replace safety signs that are missing or have become illegible.
3. Replaced parts that displayed a safety sign should also display the current sign.
4. Safety signs are available from your authorized Distributor or Dealer Parts Department or the factory.

### How to Install Safety Signs:

- Be sure that the installation area is clean and dry.
- Be sure temperature is above 50°F (10°C).
- Determine exact position before you remove the backing paper. (See Section 3).
- Remove the smallest portion of the split backing paper.
- Align the sign over the specified area and carefully press the small portion with the exposed sticky backing in place.
- Slowly peel back the remaining paper and carefully smooth the remaining portion of the sign in place.
- Small air pockets can be pierced with a pin and smoothed out using the piece of sign backing paper.

## 2.5 PREPARATION

1. Never operate the tractor and machine until you have read and completely understand this manual, the Tractor Operator's Manual, and each of the Safety Messages found on the safety signs on the tractor and machine.

2. Personal protection equipment including hard hat, safety glasses, safety shoes, and gloves are recommended during assembly, installation,



operation, adjustment, maintaining, repairing, removal, or moving the implement. Do not allow long hair, loose fitting clothing or jewellery to be around equipment.

3. **PROLONGED EXPOSURE TO LOUD NOISE MAY CAUSE PERMANENT HEARING LOSS!**

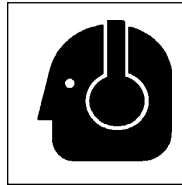

Tractors with or without equipment attached can often be noisy enough to cause permanent, partial hearing loss. We recommend that you wear hearing protection on a full-time basis if the noise in the Operator's position exceeds 80db. Noise over 85db on a long-term basis can cause severe hearing loss. Noise over 90db adjacent to the Operator over a long-term basis may cause permanent, total hearing loss. **NOTE:** Hearing loss from loud noise (from tractors, chain saws, radios, and other such sources close to the ear) is cumulative over a lifetime without hope of natural recovery.

4. Operate the machine only with a tractor equipped with an approved Roll-Over-Protective Structure (ROPS). Always wear your seat belt. Serious injury or even death could result from falling off the tractor ---particularly during a turnover when the operator could be pinned under the ROPS or the tractor.

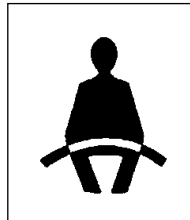

5. Clear working area of stones, branches or hidden obstacles that might be hooked or snagged, causing injury or damage.
6. Operate only in daylight or good artificial light.
7. Be sure machine is properly mounted, adjusted and in good operating condition.
8. Ensure that all safety shielding and safety signs are properly installed and in good condition.



## 2.6 OPERATING SAFETY

1. Please remember it is important that you read and heed the safety signs on the Log Grapple. Clean or replace all safety signs if they cannot be clearly read and understood. They are there for your safety, as well as the safety of others. The safe use of this machine is strictly up to you, the operator.
2. All things with moving parts are potentially hazardous. There is no substitute for a cautious, safe-minded operator who recognizes potential hazards and follows reasonable safety practices. The manufacturer has designed this Log Grapple to be used with all its safety equipment properly attached, to minimize the chance of accidents. Study this manual to make sure you have all safety equipment attached.
3. If a safety shield or guard is removed for any reason, it must be replaced before the machine is again operated.
4. Personal protection equipment including hard hat, safety glasses, hearing protection, safety shoes, and tight gloves are recommended during assembly, installation, operation, adjustment, maintaining, repairing, removal, or moving. Do not allow long hair, loose fitting clothing, or jewellery to be around moving parts.
5. Always use two people to handle heavy, unwieldy components during assembly, installation, removal or moving.
6. Never place any part of your body, fingers, hands, feet, etc. where it would be in danger if movement should occur during assembly, installation, operation, maintaining, repairing, removal or moving. Keep others away.
7. Do not allow bystanders within 20 feet of machine during operation. Logs can roll unexpectedly and injure others.
8. Do not step over or straddle logs during operation.
9. Install weights on the front of the tractor or use a tractor with a loader to maintain stability.
10. Never use alcoholic beverages or drugs which can hinder alertness or coordination while operating this equipment. Consult your doctor about operating this machine while taking prescription medications.
11. Do not allow riders on the machine or tractor at any time. There is no safe place for any riders.
12. Before you operate the machine, check over all pins, bolts, connections and hydraulic components to be sure all are securely in place and tight. Tighten or replace any leaking, damaged or worn parts immediately.
13. Do not allow anyone who is not familiar with the safety rules and operation instructions to use this machine.
14. Never allow children to operate or be around this machine.
15. Use stabilizer bars, adjustable sway chains, or sway blocks on the tractor lift arms to keep the machine from swinging side to side. Adjust as tightly as practical for best performance.
16. Do not operate on slopes or hillsides. Sloping terrain can cause logs to roll or slip.
17. Clear the work area of objects which might be picked up and snagged or entangled in the machine. Do not operate on slippery, wet, muddy or icy surfaces. Good footing prevents slipping and tripping.

## 2.7 HYDRAULIC SAFETY

1. Make sure that all the components in the hydraulic system are kept in good condition and are clean.
2. Replace any worn, cut, abraded, flattened or crimped hoses and metal lines.
3. Stop engine or motor, disconnect spark plug wire or unplug power cord, and wait for all moving parts to stop before servicing, adjusting, repairing or cleaning.
4. Do not attempt any makeshift repairs to the hydraulic lines, fittings or hoses by using tapes, clamps or cements. The hydraulic system operates under extremely high-pressure. Such repairs will fail suddenly and create a hazardous and unsafe condition.

5. Wear proper hand and eye protection when searching for a high-pressure hydraulic leak. Use a piece of wood or cardboard as a backstop instead of hands to isolate and identify a leak.

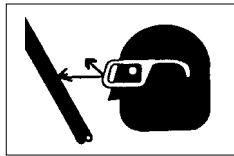

6. If injured by a concentrated high-pressure stream of hydraulic fluid, seek medical attention immediately. Serious infection or toxic reaction can develop from hydraulic fluid piercing the skin surface.
  7. Before applying pressure to the system, make sure all components are tight and that lines, hoses and couplings are not damaged.
- Think SAFETY! Work SAFELY!

## 2.8 STORAGE SAFETY

1. Store the unit in an area away from human activity.
2. Do not permit children to play on or around the stored machine.
3. Store the unit in a dry, level area. Support the frame with planks if required.

## 2.9 TRANSPORT SAFETY

1. Comply with state and local laws governing highway safety and movement of machinery on public roads.
2. The use of flashing amber lights is acceptable in most localities. However, some localities prohibit their use. Local laws should be checked for all highway lighting and marking requirements.
3. At all times, when driving the tractor and equipment on the road or highway under 20 mph (32 kph) use flashing amber warning lights and a slow moving vehicle (SMV) identification emblem. Do not exceed 20 mph (32 kph). Reduce speed on rough roads and surfaces.
4. Plan your route to avoid heavy traffic.
5. Always install transport locks, pins or brackets before transporting.
6. Do not drink and drive.
7. Be a safe and courteous driver. Always yield to oncoming traffic in all situations, including narrow bridges, intersections, etc. Watch for traffic when operating near or crossing roadways.
8. Turn into curves or go up or down hills only at a low speed and at a gradual steering angle. Make certain that at least 20% of the tractor's weight is on the front wheels to maintain safe steering. Slow down on rough or uneven surfaces.
9. A heavy load can cause instability of the tractor. Use extreme care during travel. Slow down on turns and watch out for bumps. The tractor may need front counterweights to counterbalance the weight of the machine.
10. Never allow riders on either tractor or machine.

## 2.10 MAINTENANCE SAFETY

1. Good maintenance is your responsibility. Poor maintenance is an invitation to trouble.
2. Follow good shop practices.

- Keep service area clean and dry.
- Be sure electrical outlets and tools are properly grounded.
- Use adequate light for the job at hand.

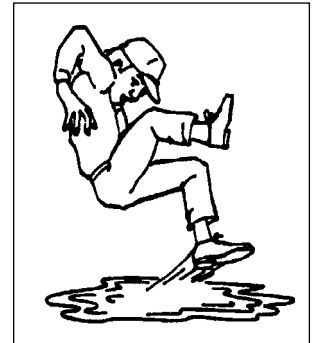

3. Make sure there is plenty of ventilation. Never operate the engine of the towing vehicle in a closed building. The exhaust fumes may cause asphyxiation.
4. Before working on this machine, shut off the engine, set the brakes, and remove the ignition keys.
6. Never work under equipment unless it is blocked securely.
7. Use personal protection devices such as eye, hand and hearing protectors, when performing any service or maintenance work.
8. Where replacement parts are necessary for periodic maintenance and servicing, genuine factory replacement parts must be used to restore your equipment to original specifications. The manufacturer will not be responsible for injuries or damages caused by use of unapproved parts and/or accessories.
9. A fire extinguisher and first aid kit should be kept readily accessible while performing maintenance on this equipment.

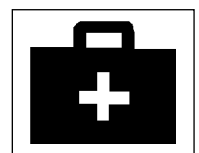
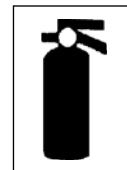

10. Periodically tighten all bolts, nuts and screws and check that all cotter pins are properly installed to ensure unit is in a safe condition.
11. When completing a maintenance or service function, make sure all safety shields and devices are installed before placing unit in service.



### 3 SAFETY SIGN LOCATIONS

The types of safety signs and locations on the equipment are shown in the illustration below. Good safety requires that you familiarize yourself with the various safety signs, the type of warning and the area, or particular function related to that area, that requires your SAFETY AWARENESS.

**A**

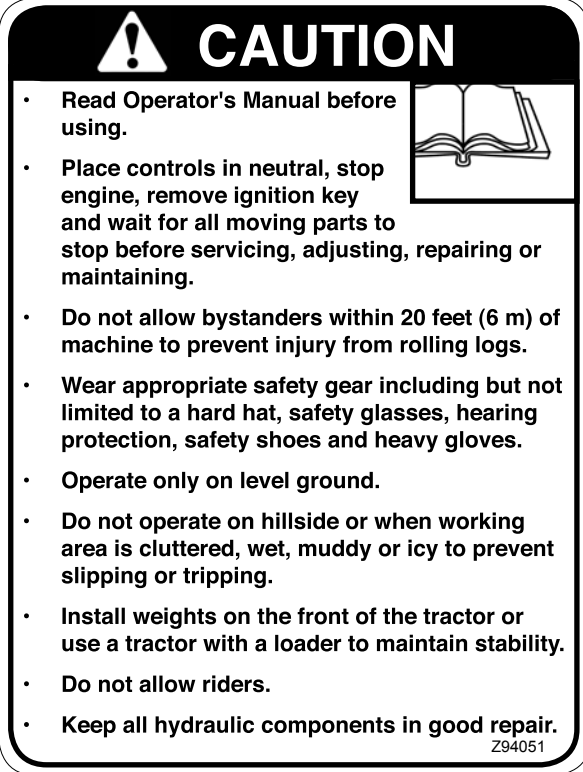

**CAUTION**

- Read Operator's Manual before using.
- Place controls in neutral, stop engine, remove ignition key and wait for all moving parts to stop before servicing, adjusting, repairing or maintaining.
- Do not allow bystanders within 20 feet (6 m) of machine to prevent injury from rolling logs.
- Wear appropriate safety gear including but not limited to a hard hat, safety glasses, hearing protection, safety shoes and heavy gloves.
- Operate only on level ground.
- Do not operate on hillside or when working area is cluttered, wet, muddy or icy to prevent slipping or tripping.
- Install weights on the front of the tractor or use a tractor with a loader to maintain stability.
- Do not allow riders.
- Keep all hydraulic components in good repair.

Z94051

**B**



**DANGER**

**GRAPPLE HAZARD  
KEEP AWAY**

To prevent serious injury or death from moving boom/grapple:

- Lower and close grapple, place all controls in neutral, stop engine, set park brake, remove ignition key and wait for all moving parts to stop before servicing, adjusting, repairing or maintaining.
- Stay back at least 20 ft. (6m) when grapple is operating.
- Keep others away.

Z94033



**REMEMBER** - If safety signs have been damaged, removed, become illegible or parts replaced without signs, new signs must be applied. New signs are available from your authorized dealer.

## 4 OPERATION



### OPERATING SAFETY

- Read Operator's Manual before using.
- Place controls in neutral, stop engine, remove ignition key and wait for all moving parts to stop before servicing, adjusting, repairing or maintaining.
- Do not allow bystanders within 20 feet (6 m) of machine to prevent injury from rolling logs.
- Wear appropriate safety gear including but not limited to a hard hat, safety glasses, hearing protection, safety shoes and heavy gloves.
- Operate only on level ground.
- Do not operate on hillside or when working area is cluttered, wet, muddy or icy to prevent slipping or tripping.
- Install weights on the front of the tractor or use a tractor with a loader to maintain stability.
- Do not allow riders.
- Keep all hydraulic components in good repair.

### 4.1 TO THE NEW OPERATOR OR OWNER

The LandMax 3 Point Hitch Log Grapple is designed to grab and pull any kind of wood or log. Be familiar with the machine before starting.

**In addition to the design and configuration of equipment, hazard control and accident prevention are dependent upon the awareness, concern, prudence and proper training of personnel involved in the operation, transport, maintenance and storage of equipment. It is the responsibility of the owner or operator to read this manual and to train all other operators before they start working with the machine.**

**It is the responsibility of the owner or operator to read this manual and to train all other operators before they start working with the machine. Follow all safety instructions exactly. Safety is everyone's business. By following recommended procedures, a safe working environment is provided for the operator, bystanders and the area around the work site. Untrained operators are not qualified to operate the machine.**

Many features incorporated into this machine are the result of suggestions made by customers like you. Read this manual carefully to learn how to operate the machine safely and how to set it to provide maximum field efficiency. By following the operating instructions in conjunction with a good maintenance program, your Log Grapple will provide many years of trouble-free service.

## 4.2 MACHINE COMPONENTS

The LandMax 3 Point Hitch Log Grapple consists of a grapple on the end of a frame that mounts to the 3 Point Hitch on a tractor for grasping and picking up wood or logs. Hydraulic power

from the tractor is routed through a double acting valve to control the cylinder position. The grapple is designed to pivot and swivel to align the log behind the tractor.

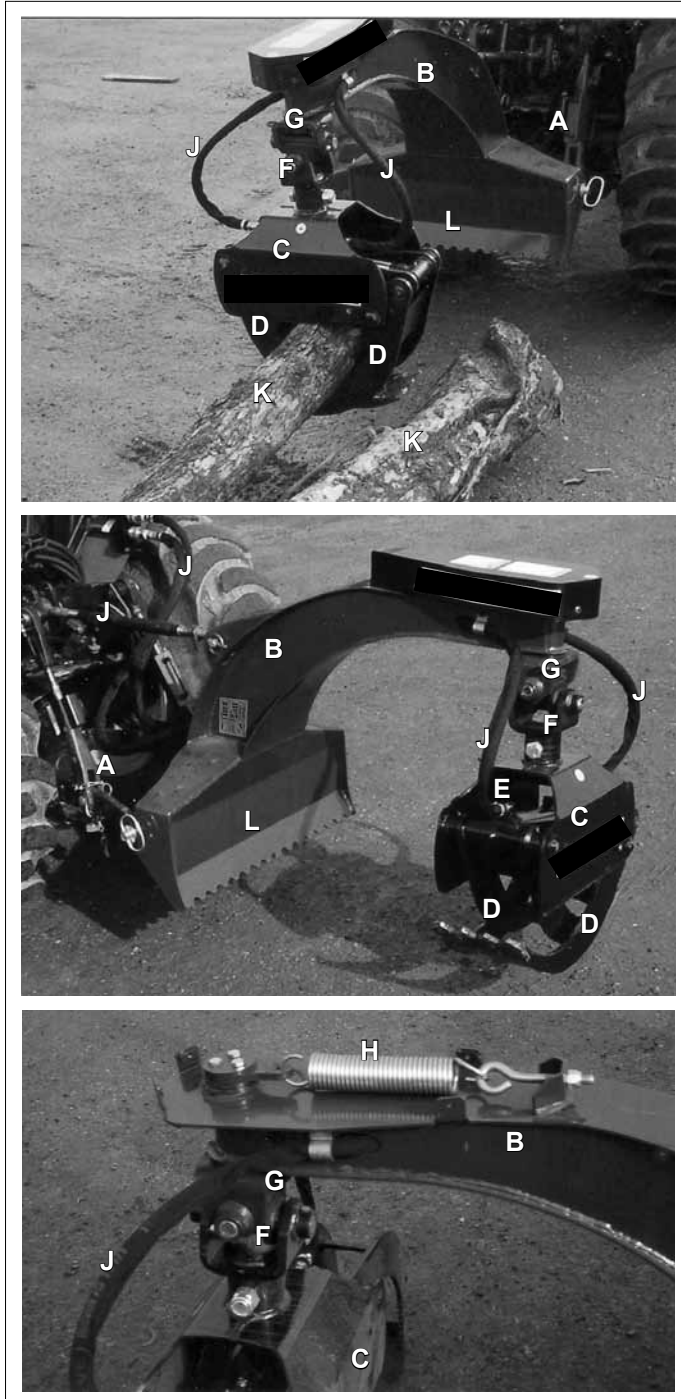

- A Mounting Frame
- B Main Frame
- C Grapple Frame
- D Grapple Claws
- E Hydraulic Cylinder
- F Pivot
- G Swivel
- H Centering Spring
- J Hydraulic Hose
- K Log(s)
- L Log Pivot Anchor

**⚠ DANGER**

**MISSING SHIELD HAZARD**

- Install and secure all shields before operating to prevent serious injury or death from exposed hazard.
- Keep hands, feet, hair and clothing away from moving parts.

Fig. 1 MACHINE COMPONENTS

## 4.3 MACHINE BREAK-IN

Although there are no operational restrictions on the Log Grapple when used for the first time, it is recommended that the following mechanical items be checked:

### A. After Operating For 1 and 5 Hours:

1. Check all nuts, bolts and other fasteners. Tighten to their specified torque level.
2. Check hydraulic system for leaks. Tighten all leaking fittings and replace any leaking components.
3. Then go to the service schedule as defined in the Maintenance Section.

## 4.4 PRE-OPERATION CHECKLIST

Efficient and safe operation of the LandMax Grapple requires that each operator reads and understands the operating procedures and all related safety precautions outlined in this section. A pre-operation checklist is provided for the operator. It is important for both the personal safety and maintaining the good mechanical condition of the Log Grapple that this checklist is followed.

Before operating the machine and each time thereafter, the following areas should be checked off:

1. Use only a small Agricultural tractor or compact tractor of less than 60 horsepower on the machine.
2. Check that the machine is properly attached to the tractor. Be sure retainers are used on the mounting pins.
3. Be sure extra weights are mounted on the front of the tractor if required.
4. Check the grapple claws. Be sure they are not bent or broken. Repair or replace as required.
5. Check for entangled material. Remove this material.
6. Check for hydraulic leaks. Tighten fittings or replace components to stop leaks.



## 4.5 ASSEMBLY

The machine is shipped from the factory in a partially disassembled configuration and attached to a pallet that provides easy moving and handling. Always use tools, equipment and fork lifts of appropriate size and capacity for the job. Always use 2 men when lifting, moving and assembling the machine.

**When the machine is shipped, follow this procedure when preparing for the customer:**

1. Clear the area of bystanders, especially small children.
2. Remove the pallet tie-downs.
3. Use a forklift to lift the pallet/machine from the truck. Carry the load close to the ground as it is moved to the assembly area and positioned.
4. Attach to a tractor:
  - a. Place tractor lift arms in their fully away configuration.
  - b. Back up and align arms with mounting pins.
  - c. Remove mounting pins.
  - d. Move lift arms into position.
  - e. Install mounting pins and retainers.



**Fig. 2 SHIPPING CONFIGURATION (typical)**

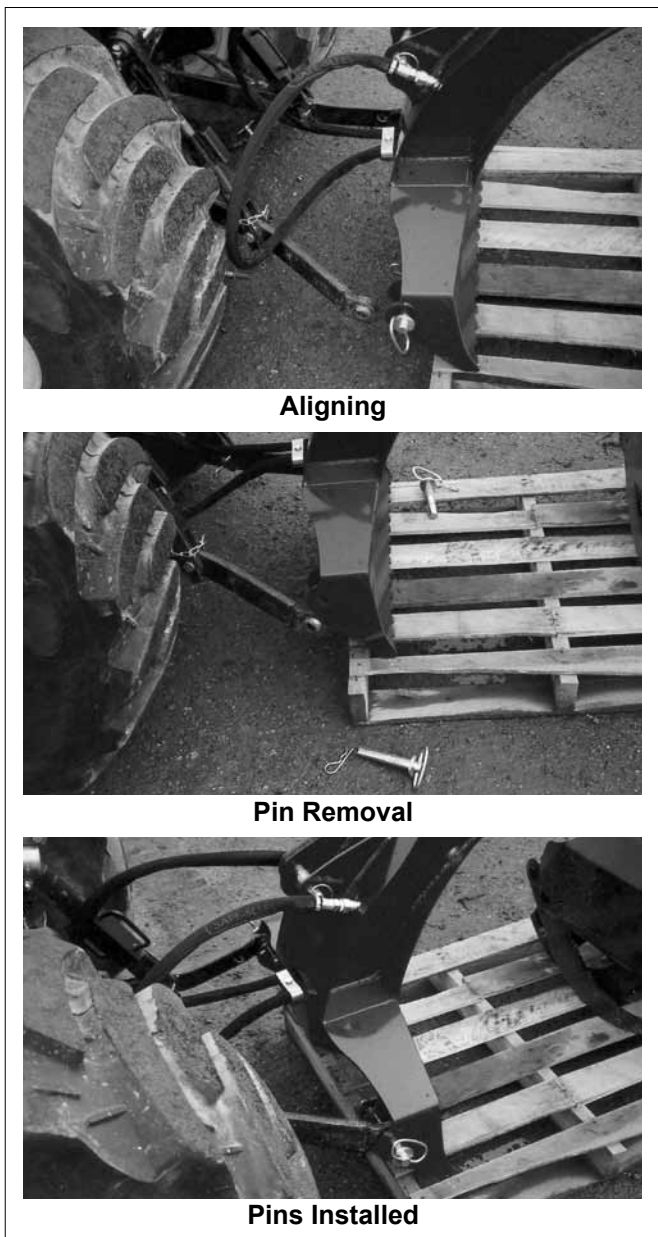

**Fig. 3 ATTACHING**

5. **Connect the hydraulics:**

- a. Use a clean rag or paper towel to clean the dirt from couplers on the hose ends and the tractor.
- b. Connect the hoses to the tractor couplers. Be sure the couplers are securely seated.
- c. Route and secure the hoses along the hitch with clips, tape or plastic ties to prevent binding and pinching.

**NOTE**

Do not connect to the hydraulic circuit with a detent.



6. Attach top link and secure with retainer.

7. Raise frame and remove pallet.
8. Set the 3 Point Hitch in the non-sway position (see tractor manual for details).



**First Hose**



**Second Hose**

**Fig. 4 HYDRAULICS**



**Fig. 5 TOP LINK**



**Fig. 6 MOUNTED**

## 4.6 EQUIPMENT MATCHING

To insure the safe and reliable operation of the Log Grapple, it is necessary to use a tractor with the correct specifications. Use the following list as a guide in selecting a tractor to use on the machine.

**1. Horsepower:**

Although horsepower is not required to operate the Log Grapple, it does establish the total weight for machine stability. Do not exceed the Log Grapple power specifications.

**2. Tractor Weight:**

It is recommended that the tractor be equipped with a full complement of front end weights or a loader to balance the 3 point hitch weight loading.

**3. Hydraulic System:**

The tractor hydraulic system must be capable of 5 gpm (19 lpm) a 2000 psi (13,800 kPa).

**4. 3 Point Hitch:**

The tractor must be equipped with a Category 1 3 point hitch to match the log grapple.

**Table 1: Model vs. Tractor HP**

Model	Recommended Tractor Horsepower
LX5100	25 - 45



**Fig. 7 3 POINT HITCH (typical)**

## 4.7 CONTROLS

Always review the "controls" section of the tractor operator's manual to be familiar with the location, settings and function of the controls. Be familiar with the controls before starting.

## 4.8 ATTACHING/UNHOOKING TRACTOR

When attaching log grapple to a tractor, follow this procedure:

1. Clear the area of bystanders, especially small children.
2. Make sure there is enough room and clearance to safely back up to the log grapple.
3. Place the tractor arms in their full sway position.
4. Back up slowly and align the lower link arms to the pins on the machine.

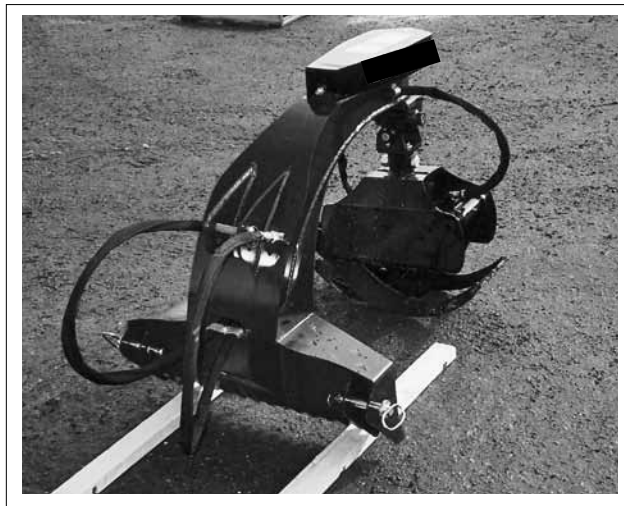

Fig. 8 STORED

### 5. Mounting without a Quick Hitch

- a. Remove mounting pins and retainers.
- b. Align the left lower link with the left mounting pin.

#### **IMPORTANT**

It may be necessary to add weight to the lower lift arms to bring them to the required height.

- c. Insert the left pin through the ball and install the retainer.
- d. Align the right arm to the pin by turning the jackscrew on the arm.
- e. Insert the right pin through the ball and install the retainer. Return the jackscrew to its starting position.



Pins Removed



Left Pin

Fig. 9 LOWER ARMS

6. **Connect the hydraulics:**

- a. Use a clean rag or paper towel to clean the dirt from couplers on the hose ends and the tractor.
- b. Connect the hoses to the tractor couplers. Be sure the couplers are securely seated.
- c. Route and secure the hoses along the hitch with clips, tape or plastic ties to prevent binding and pinching.

**NOTE**

Do not connect to the hydraulic circuit with a detent.

 <b>WARNING</b>	
	
<b>HIGH PRESSURE FLUID HAZARD</b> To prevent serious injury or death from high-pressure fluid:	
<ul style="list-style-type: none"><li>• Relieve pressure on system before repairing or adjusting.</li><li>• Wear proper hand and eye protection when searching for leaks. Use wood or cardboard instead of hands.</li><li>• Keep all components in good repair.</li></ul>	

7. Remove the top pin and install the top link. Use the turnbuckle to align the top link. Insert the pins and install the retainers. Return the turnbuckle to its original length and lock.

**IMPORTANT**

Move or remove the tractor drawbar if there is interference between the mounting frame and drawbar. Check the tractor manual if required.



**First Hose**



**Second Hose**

**Fig. 10 HYDRAULICS**

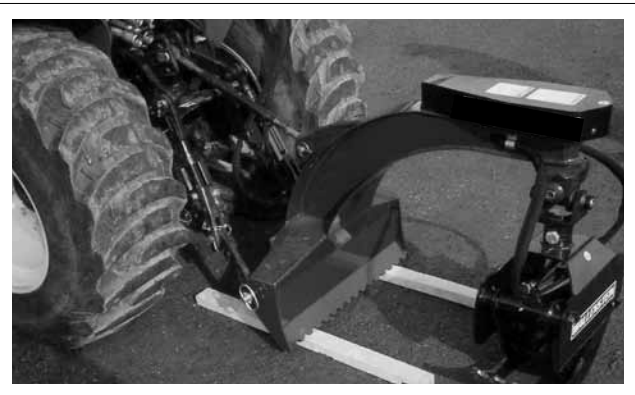

**Fig. 11 TOP LINK**



**Fig. 12 DRAWBAR**

## 8. Mounting with a Quick Hitch.

- a. Align the claws on the Quick Hitch slightly below the mounting pins on the log grapple.

### **IMPORTANT**

It may be necessary to add weight to the lower lift arms to bring them to the required height.

- b. Back up until the pins are above the claws.
  - c. Use the turnbuckle on the top link to adjust the position of the top claw.
  - d. Raise the 3 point hitch until the pins seat in the claws.
  - e. Be sure the retainers are released to hold the pins in the claws.
9. Set the 3 point hitch in the non-sway position (see tractor manual for details).
  10. Move the log grapple hydraulic lever to move the claws.
  11. Reverse the hoses if the claws do not move in the same direction as the hydraulic lever.
  12. Slowly raise the machine through its operating range to make sure that there is no interference or binding.
  13. Level the machine front and rear, and side to side using the jackscrew on the right arm and the turnbuckle on the top link.
  14. To unhook from the tractor, reverse the above procedure. Park the machine in a dry, level area. Always place a couple of planks or boards under the frame when unhooking to provide support for the machine.

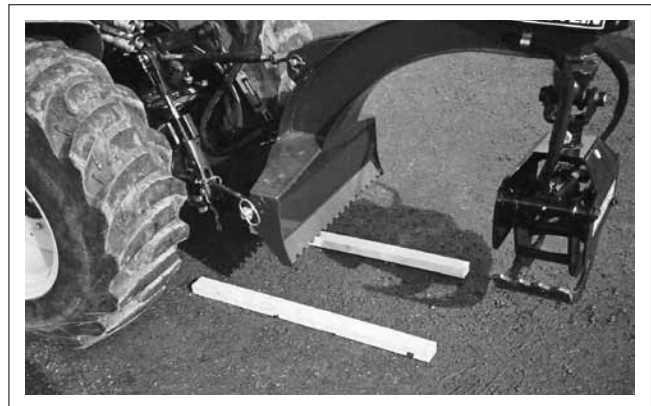

**Fig. 11 LEVELLING ADJUSTMENTS**

## 4.9 FIELD OPERATION



### OPERATING SAFETY

- Read Operator's Manual before using.
- Place controls in neutral, stop engine, remove ignition key and wait for all moving parts to stop before servicing, adjusting, repairing or maintaining.
- Do not allow bystanders within 20 feet (6 m) of machine to prevent injury from rolling logs.
- Extend stabilizers to support frame during loading and unloading.
- Wear appropriate safety gear including but not limited to a hard hat, safety glasses, hearing protection, safety shoes and heavy gloves.
- Operate only on level ground.
- Do not operate on hillside or when working area is cluttered, wet, muddy or icy to prevent slipping or tripping.
- Install weights on the front of the tractor or use a tractor with a loader to maintain stability.
- Do not allow riders.
- Keep all hydraulic components in good repair.

LandMax Log Grapples attach to a tractor 3 point hitch and use the tractor hydraulics to open and close the grapple claws. However the operator has the responsibility of being familiar with all operating and safety procedures and following them.

Each operator should review this section of the manual at the start of the season and as often as required to be familiar with the machine. When using, follow this procedure:

1. Clear the area of bystanders, especially small children.
2. Review and follow the Pre-Operation Checklist (Section 4.4).
3. Attach the machine to the tractor (Section 4.6).

**4. Starting:**

- a. Align the tractor/machine with the logs, poles or wood.
- b. Back the grapple claws over one end of the log.
- c. Open the grapple claws and lower the grapple over the log.



**Positioning**

- d. Close the grapple.
- e. Lift the frame and log.



**Lifting**

**Fig. 14 STARTING**



5. **Log Placement:**

The grapple can be used in many ways to lift and move logs. Some typical uses include but are not limited to:

- a. Lifting logs onto a trailer.
- b. Piling logs.



**Piling**

- c. Towing or pulling logs.



**Towing**

**Fig. 15 APPLICATIONS (Typical)**

6. **Misalignment:**

The frame of the jaws is spring-loaded-to-center to allow the grapple to work when the log is not aligned.

- a. Open the jaws fully.
- b. Back up and align as best you can.
- c. Lower 3 Point Hitch.
- d. Close jaws.
- e. Raise frame and move forward.



**Open Jaws**



**Lowered**



**Close Jaws**



**Moving**

**Fig. 16 MISALIGNED**

7. **Pivot:**

The frame is designed with a pivot that is spring-loaded to keep it centered behind the tractor. It can be overloaded and stretched or broken in unusual operating conditions. Tighten with the adjusting bolt if stretched or replace if broken.

 **DANGER**

**MISSING SHIELD HAZARD**

- Install and secure all shields before operating to prevent serious injury or death from exposed hazard.
- Keep hands, feet, hair and clothing away from moving parts.



**Spring**



**Aligned**

**Fig. 17 CENTERING SPRING**

8. **Ballasting:**

It is recommended that the tractor be equipped with a loader or a full complement of front suitcase weights to balance the weight of the Log Grapple.



**Fig. 18 BALANCING**

9. **Log Size:**

The jaws of the Log Grapple do not open as large as the inside portion of the claws. Do not overload the frame. Measure the size of the log ahead of time to determine if the log is too large.

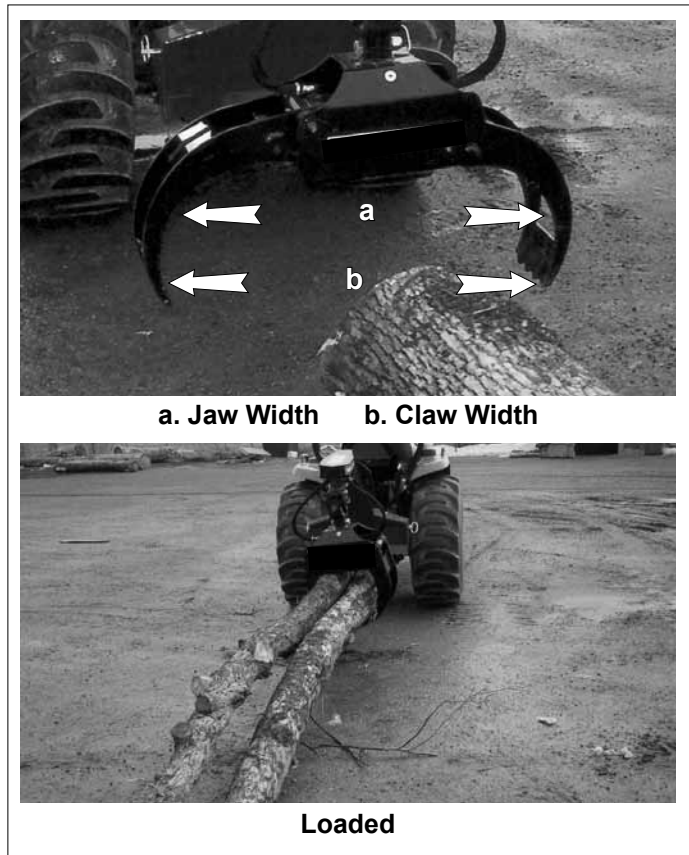

Fig. 19 LOG SIZE

10. **Operating Hints:**

- a. Do not overload the machine by trying to pick up a log that is too heavy. Use an alternative method to move the log.
- b. Use a tractor that is equipped with a front end loader or has a full complement of suitcase weights on the front to balance the weight on the 3 point hitch. This balancing will insure the required weight on the front of the tractor to provide steering control.
- c. Do not exceed the recommended size of the tractor for the grapple. A tractor that is too large can overload the frame and cause failures.



Fig. 20 LIFTING

## 4.10 TRANSPORTING



### TRANSPORT SAFETY

1. Comply with state and local laws governing highway safety and movement of machinery on public roads.
2. The use of flashing amber lights is acceptable in most localities. However, some localities prohibit their use. Local laws should be checked for all highway lighting and marking requirements.
3. At all times, when driving the tractor and equipment on the road or highway under 20 mph (32 kph) use flashing amber warning lights and a slow moving vehicle (SMV) identification emblem. Do not exceed 20 mph (32 kph). Reduce speed on rough roads and surfaces.
4. Plan your route to avoid heavy traffic.
5. Always install transport locks, pins or brackets before transporting.
6. Do not drink and drive.
7. Be a safe and courteous driver. Always yield to oncoming traffic in all situations, including narrow bridges, intersections, etc. Watch for traffic when operating near or crossing roadways.
8. Turn into curves or go up or down hills only at a low speed and at a gradual steering angle. Make certain that at least 20% of the tractor's weight is on the front wheels to maintain safe steering. Slow down on rough or uneven surfaces.
9. A heavy load can cause instability of the tractor. Use extreme care during travel. Slow down on turns and watch out for bumps. The tractor may need front counterweights to counterbalance the weight of the machine.
10. Never allow riders on either tractor or machine.

When transporting the machine, review and follow these instructions:

1. Be sure all bystanders are clear of the machine.
2. Be sure that the machine is securely attached to the tractor and all retainer pins are installed.
3. Be sure you have installed extra weights on the front of the tractor if required.
4. Clean the SMV emblem, lights and reflectors and be sure they are working.
5. Be sure you are in compliance with all applicable lighting and marking regulations when transporting. Check with your local authorities.
6. Be sure your machine can clearly be seen by overtaking and oncoming traffic.
7. Keep to the right and yield the right-of-way to allow faster traffic to pass. Drive on the road shoulder if permitted by law.

8. Do not allow riders.
9. Always use hazard flashers on the tractor when transporting unless prohibited by law.



Fig. 21 TRANSPORTING

## 4.11 STORAGE



### STORAGE SAFETY

- Store the unit in an area away from human activity.
- Do not permit children to play on or around the stored machine.
- Store the unit in a dry, level area. Support the frame with planks if required.

After the season's use, the machine should be thoroughly inspected and prepared for storage. Repair or replace any worn or damaged components to prevent any unnecessary down time at the start of next season. To insure a long, trouble free life, this procedure should be followed when preparing the unit for storage:

1. Clear the area of bystanders, especially small children.
2. Thoroughly wash the machine using a pressure washer to remove all dirt, mud, debris and residue.
3. Inspect the cylinder and grapple for damage or entangled material. Repair or replace damaged parts. Remove all entangled material.
4. Touch up all paint nicks and scratches to prevent rusting.
5. Move to storage area.
6. Select an area that is dry, level and free of debris.
7. Fully retract the cylinder ram.
8. Unhook from tractor.
9. If the machine cannot be placed inside, cover with a waterproof tarpaulin and tie securely in place.
10. Store the machine in an area away from human activity.
11. Do not allow children to play on or around the stored machine.



Fig. 22 STORED

## 5 SERVICE AND MAINTENANCE



### MAINTENANCE SAFETY

- Follow ALL the operating, maintenance and safety information in the manual.
- Support the machine with blocks or safety stands when working beneath it.
- Follow good shop practices.
  - Keep service area clean and dry.
  - Be sure electrical outlets and tools are properly grounded.
  - Use adequate light for the job at hand.
- Make sure there is plenty of ventilation. Never operate the engine of the towing vehicle in a closed building. The exhaust fumes may cause asphyxiation.
- Use only tools, jacks and hoists of sufficient capacity for the job.
- Make sure all guards are in place and properly secured when maintenance work is completed.
- Keep hands, feet, hair and clothing away from moving or rotating parts.
- Clear the area of bystanders, especially small children, when carrying out any maintenance and repairs or making any adjustments.

## 5.1 SERVICE

### 5.1.1 FLUIDS AND LUBRICANTS

1. **Grease:**  
Use an SAE multi-purpose high temperature grease with extreme pressure (EP) performance. Also acceptable is an SAE multipurpose lithium base grease.
2. **Storing Lubricants:**  
Your machine can operate at top efficiency only if clean lubricants are used. Use clean containers to handle all lubricants. Store them in an area protected from dust, moisture and other contaminants.

### 5.1.2 GREASING

Use the Maintenance Checklist provided to keep a record of all scheduled maintenance.

1. Use a hand-held grease gun for all greasing.
2. Wipe grease fitting with a clean cloth before greasing to avoid injecting dirt and grit.
3. Replace and repair broken fittings immediately.
4. If fittings will not take grease, remove and clean thoroughly. Also clean lubricant passage. Replace fitting if necessary.

### 5.1.3 SERVICING INTERVALS

The period recommended is based on normal operating conditions. Severe or unusual conditions may require more frequent servicing.

#### 8 Hours or Daily

1. Grease the pins.
  - a. Pivot pin.
  - b. Swivel pin.
  - c. Grapple pins.

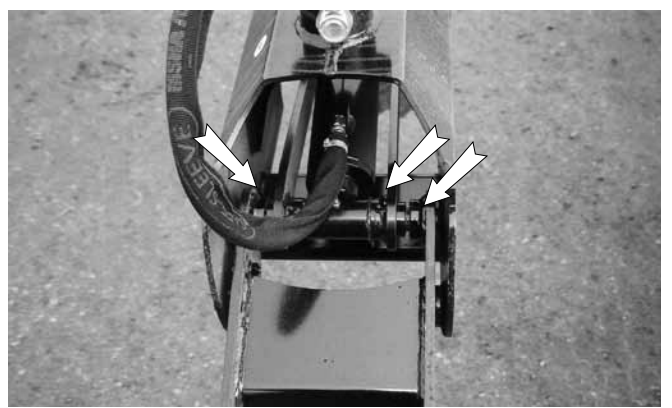

Left Side

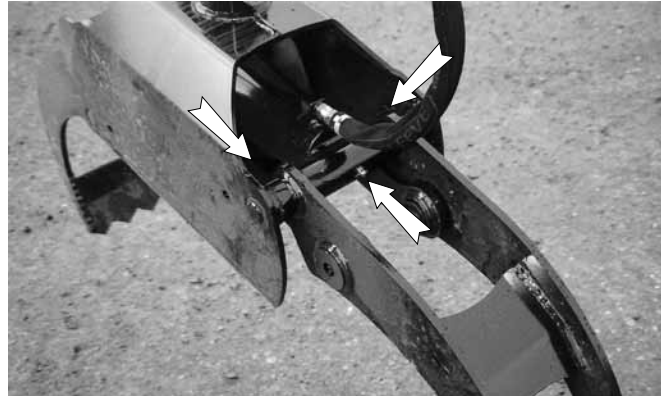

Right Side

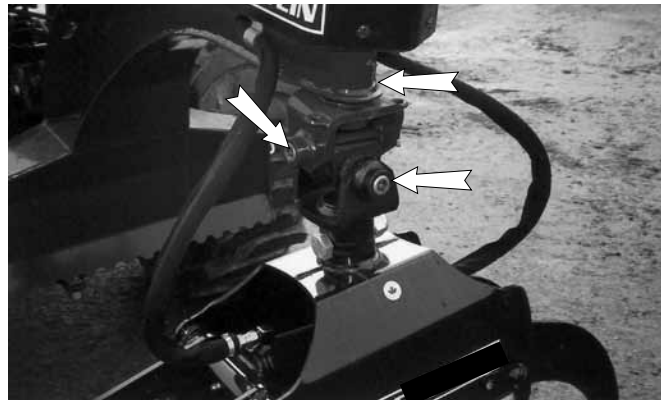

Rear

Fig. 23 PINS

#### Annually

1. Wash and clean machine.

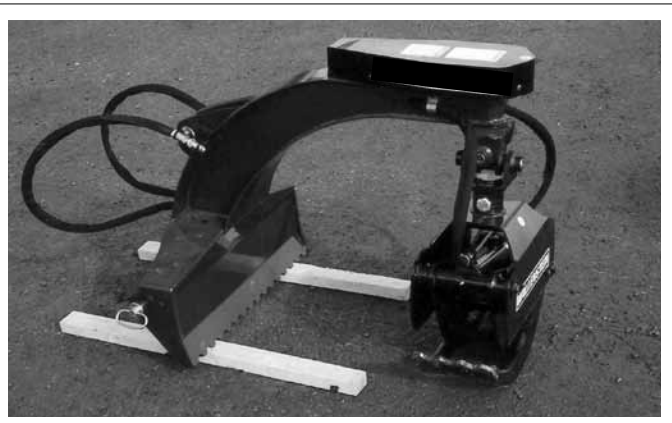

Fig. 24 LX5100





## 6 TROUBLE SHOOTING

The LandMax 3 Point Hitch Mounted Log Grapple uses tractor hydraulic power to open and close a grapple to hold and lift logs. It is a simple and reliable system that requires minimal maintenance.

In the following section, we have listed many of the problems, causes and solutions to the problems that you may encounter.

If you encounter a problem that is difficult to solve, even after having read through this trouble shooting section, please call your local dealer. Before you call, please have this Operator's Manual and the serial number from your Log Grapple ready.

<b>PROBLEM</b>	<b>CAUSE</b>	<b>SOLUTION</b>
Grapple claws don't move.	No oil.	Use a different remote outlet.  Check tractor oil level. Top up as required.
<hr/>		
Grapple claws move in wrong direction.	Hydraulic hoses reversed.	Reverse hoses.

# 7 SPECIFICATIONS

## 7.1 MECHANICAL

<b>Model</b>	<b>LX5100</b>
<b>Overall Length/Width/Hieght</b>	41" / 29" / 32"
<b>Total Weight</b>	275 lb
<b>Grapple Rotation</b>	180°
<b>Grapple Opening</b>	3" 38"
<b>3 Point Hitch Category</b>	Cat 1
<b>Max. Boom Lift Capacity</b>	1500 lb
<b>Recommended Tractor Size</b>	20 - 45 hp

**SPECIFICATIONS ARE SUBJECT TO CHANGE WITHOUT NOTICE**

## 7.2 HYDRAULIC FITTING TORQUE

### Tightening Flare Type Tube Fittings \*

1. Check flare and flare seat for defects that might cause leakage.
2. Align tube with fitting before tightening.
3. Lubricate connection and hand tighten swivel nut until snug.
4. To prevent twisting the tube(s), use two wrenches. Place one wrench on the connector body and with the second tighten the swivel nut to the torque shown.

Tube Size OD	Nut Size Across Flats	Torque Value*		Recommended Turns To Tighten (After Finger Tightening)	
		(N.m)	(lb-ft)	(Flats)	(Turn)
3/16	7/16	8	6	1	1/6
1/4	9/16	12	9	1	1/6
5/16	5/8	16	12	1	1/6
<b>3/8</b>	<b>11/16</b>	<b>24</b>	<b>18</b>	<b>1</b>	<b>1/6</b>
1/2	7/8	46	34	1	1/6
5/8	1	62	46	1	1/6
3/4	1-1/4	102	75	3/4	1/8
7/8	1-3/8	122	90	3/4	1/8

- The torque values shown are based on lubricated connections as in reassembly.

## 7.3 BOLT TORQUE

### CHECKING BOLT TORQUE

#### IMPERIAL TORQUE SPECIFICATIONS

Bolt Diameter "A"	Bolt Torque*					
	SAE 2 (N.m) (lb-ft)		SAE 5 (N.m) (lb-ft)		SAE 8 (N.m) (lb-ft)	
1/4"	8	6	12	9	17	12
5/16"	13	10	25	19	36	27
3/8"	27	20	45	33	63	45
7/16"	41	30	72	53	100	75
1/2"	61	45	110	80	155	115
9/16"	95	60	155	115	220	165
5/8"	128	95	215	160	305	220
3/4"	225	165	390	290	540	400
7/8"	230	170	570	420	880	650
1"	345	225	850	630	1320	970

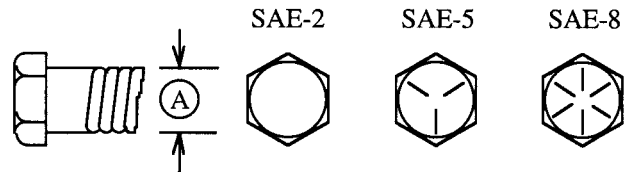

#### METRIC TORQUE SPECIFICATIONS

Bolt Diameter "A"	Bolt Torque*			
	8.8 (N.m) (lb-ft)		10.9 (N.m) (lb-ft)	
M3	.5	.4	1.8	1.3
M4	3	2.2	4.5	3.3
M5	6	4	9	7
M6	10	7	15	11
M8	25	18	35	26
M10	50	37	70	52
M12	90	66	125	92
M14	140	103	200	148
M16	225	166	310	229
M20	435	321	610	450
M24	750	553	1050	774
M30	1495	1103	2100	1550
M36	2600	1917	3675	2710

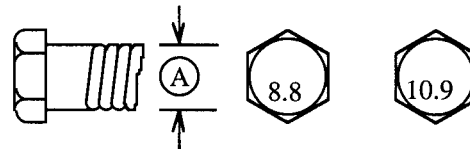

Torque figures indicated above are valid for non-greased or non-oiled threads and heads unless otherwise specified. Therefore, do not grease or oil bolts or capscrews unless otherwise specified in this manual. When using locking elements, increase torque values by 5%.

\* Torque value for bolts and capscrews are identified by their head markings.

# 8 INDEX

I	PAGE
Introduction.....	1

O	
Operation.....	12
Assembly .....	15
Attaching/Unhooking Tractor.....	18
Controls.....	17
Equipment Matching .....	17
Field Operation .....	21
Machine Break-In.....	14
Machine Components .....	13
Pre-Operation Checklist.....	14
Storage .....	28
To the New Operator or Owner .....	12
Transporting .....	27

S	PAGE
Safety .....	2
Employee Sign-Off Form.....	10
Equipment Safety Guidelines.....	4
General Safety .....	3
Hydraulic Safety.....	8
Maintenance Safety .....	9
Operating Safety .....	7
Preparation .....	6
Safety Training.....	5
Safety Signs.....	5
Sign-Off Form.....	9
Storage Safety .....	8
Transport Safety.....	9
Safety Sign Locations.....	11
Service and Maintenance.....	29
Service .....	29
Fluid and Lubricants.....	29
Greasing .....	29
Service Record .....	31
Servicing Intervals.....	30
Specifications .....	33
Bolt Torque .....	34
Hydraulic Fitting Torque .....	33
Mechanical.....	33

T	
Trouble Shooting .....	32

# ZD100 PARTS ILLUSTRATION

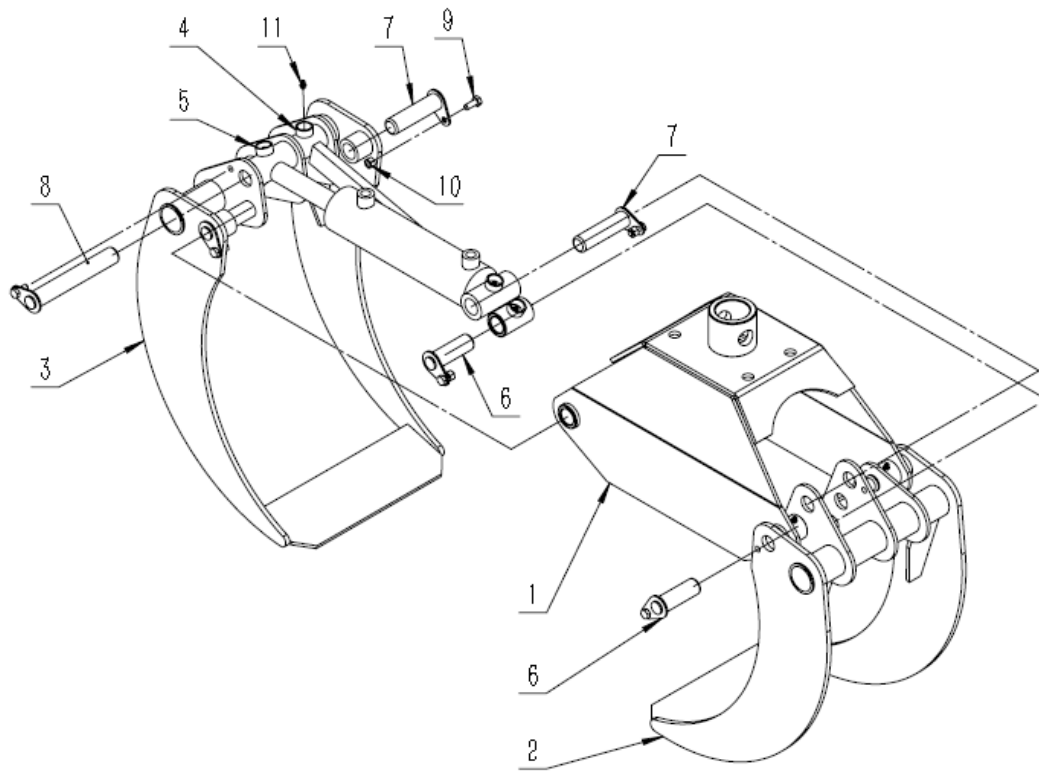

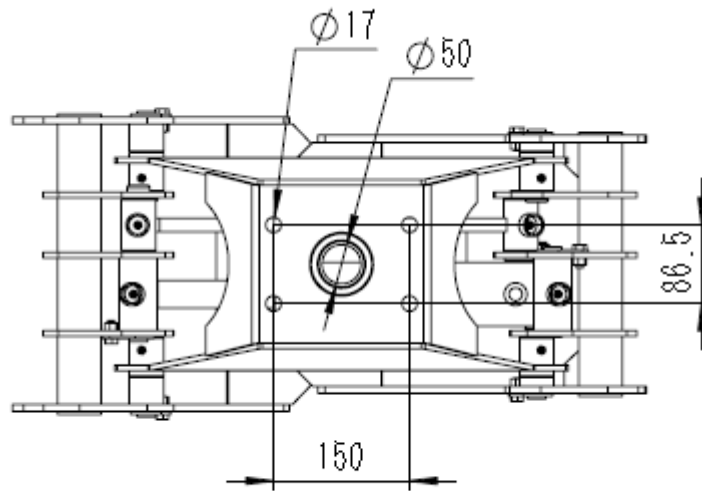

ZD100.001 PARTS LIST			
ITEM	PART NO.	DESCRIPTION	QTY.
1	ZD100.011	BODY, WELDMENT	1
2	ZD100.012	GRASPER, RIGHT	1
3	ZD100.013	GRASPER, LEFT	1
4	ZD100.014	CONNECTING ROD	1
5	ZD100.018	CYLINDER, ASSEMBLY	1
6	ZD100.015	78 PIN	3
7	ZD100.016	97 PIN	3
8	ZD100.017	170 PIN	1
9	GB5783-M8x20	BOLT M8x20	7
10	GB889.1-M8	LOCK NUT M8	7
11	JB / T7940.1-M6	ZERK M6	6