



LandMax

Suppliers Of Quality Agricultural Machinery

21 Plummers Point Road, Tauranga



Flail Mower

Eco-Mow

Operator's Manual

FOREWORD

This manual is designed to assist you in the operation and maintenance of your Flail mower. Please read it thoroughly before using and maintaining the mower. It includes information on specifications, construction, operation instructions, and maintenance procedures. Note that some information may be general due to varying conditions and unknown factors. However, with experience and the guidance provided, you should be able to develop operating procedures suited to your specific needs.

The contents of this manual may differ slightly from the Flail mower you have purchased due to ongoing improvements and developments. Specifications and design may change without notice.

We strive to ensure this manual is as accurate as possible. However, we do not guarantee the accuracy or currency of the information provided and assume no liability for any errors or omissions.

Edited

August, 2024

CONTENTS

- 1. SAFETY PRECAUTIONS 3**
 - 1.1 Safety First..... 3
 - 1.2 General Safety 3
 - 1.3 Operating Safety..... 4
 - 1.4 Storage Safety 4
 - 1.5 Maintenance Safety 5
 - 1.6 Safety & Model Decals 7
- 2. PRODUCT SPECIFICATIONS 9**
 - 2.1 Implement Specifications..... 9
 - 2.2 Identification of the implement 10
- 3. OPERATION 11**
 - 3.1 Checking Before Operating 11
 - 3.2 Adjustments 11
 - 3.3 Drive Belt Adjustment 12
 - 3.4 Starting Up 13
 - 3.5 Hydraulic Connection 14
 - 3.6 Greasing and Lubrication 14
- 4. SERVICE AND MAINTENANCE 15**
 - 4.1 Service..... 15
 - 4.2 Maintenance 15
- 5. STORAGE 18**
 - 5.1 Operation After Storage..... 18
- 6. TROUBLESHOOTING 19**
- 7. PARTS LISTS 20**

1. SAFETY PRECAUTIONS



WARNING

Before operating the Flail mower, read the following safety instructions. Failure to comply with these warnings may result in serious injury or death.

1.1 Safety First

YOU are responsible for the SAFE operation and maintenance of your Flail mower. YOU must ensure that you and anyone else who is going to operate, maintain or work around the Flail mower is familiar with the operating and maintenance procedures and related SAFETY information contained in this manual. This manual will take you step-by-step through your working day and alert you to all good safety practices that should be adhered to while operating the Flail mower.

Remember, YOU are the key to safety. Good safety practices not only protect you but also the people around you. Make these practices a working part of your safety program. Be certain that EVERYONE operating this equipment is familiar with the recommended operating and maintenance procedures and follows all the safety precautions. Most accidents can be prevented. Do not risk injury or death by ignoring good safety practices.

- Flail mower owners must give operating instructions to operators or employees before allowing them to operate the machine.
- The most important safety feature on this equipment is a SAFE operator. It is the operator's responsibility to read and understand ALL Safety and Operating instructions in the manual and to follow these. All accidents can be avoided.
- A person who has not read and understood all operating and safety instructions is not qualified to operate the machine. An untrained operator jeopardies himself and bystanders to possible serious injury or death.
- Do not modify the equipment in any way. Unauthorized modification may weaken the function and/or safety and could affect the life of the equipment.
- Think SAFETY! Work SAFELY!

1.2 General Safety

1. Read the operator's Manual and all safety signs carefully before operating, maintaining, adjusting or removing the Flail mower.
2. Do not allow passengers to ride on the Flail mower
3. Operate only at safe distance from bystanders. Clear the area of people, especially small children, before starting.
4. Stop PTO before dismounting tractor.
5. Keep feet and hands from under Flail mower at all times.
6. Keep all shields in place. If shield removal becomes necessary for repairs, replace the shield prior to use.
7. Do not stay between the tractor and the Flail mower.
8. Do not approach the Flail mower until all motion has stopped.
9. All rotary blades have the ability to discharge objects at high speeds, which could result in serious injury to bystanders or passers-by, use with extreme caution.
10. Place all controls in neutral, stop tractor engine, set park brake, remove ignition key and wait for all moving parts to stop before servicing, adjusting, repairing, attaching or removing.

-
11. Review safety related items annually with all personnel who will operate or maintain the Flail mower.
 12. Do not operate machine if you feel unwell or physically unfit, in which case you should stop working.
 13. This machine was designed with safety very much in mind. However, there is no real substitute for caution and attention in preventing accidents. Once an accident has happened, it is too late to think about what you should have done.
 14. Use a tractor equipped with a Roll Over Protective Structure (ROPS). Always wear your seat belt. Serious injury or even death could result from falling off the tractor – particularly during a turnover when the operator could be pinned under the ROPS or the tractor.
 15. Never exceed the limits of a piece of machinery. If its ability to do a job, or to do so safely, is in question – DON'T TRY IT.
 16. Clear working area of stones, branches or hidden obstacles that might be hooked or snagged, causing injury or damage.

1.3 Operating Safety

1. Read and understand the Operator's Manual and all safety signs before operating, servicing, adjusting, repairing or removing.
2. Do not allow riders.
3. Install and secure all guards and shields before starting or operating.
4. Keep hands, feet, hair and clothing away from moving parts.
5. Place all controls in neutral, stop tractor engine, set park brake, remove ignition key and wait for all moving parts to stop before servicing, adjusting, repairing, attaching or removing.
6. Place all tractor and machine controls in neutral before starting.
7. Never start or operate machine unless sitting on tractor seat.
8. Clear the area of bystanders, especially small children, before starting.
9. Stay away from PTO shaft and machine when engaging PTO. Keep others away.
10. Use warning lights on tractor when transporting.
11. Do not put hands or feet under machine while tractor engine or machine is running.
12. Do not operate Flail mower in the raised position.
13. Objects can be thrown out from under machine with sufficient force to severely injure people. Stay away from machine when it is running. Keep others away.
14. Always know what you are cutting. Never operate the Flail mower in an area that has hidden obstacles. Remove sticks, stones, wire or other objects from working area before starting.
15. Review safety instructions with all operators annually.

1.4 Storage Safety

1. Store the machine in an area away from human activity.
2. Do not permit children to play on or around the stored machine.
3. Store the machine in a dry, level area.
4. Clean grease and oil as required and protect it from the elements.

1.5 Maintenance Safety

1. Good maintenance is your responsibility. Poor maintenance is an invitation to trouble.
2. Follow good shop practices.
3. Keep service area clean and dry.
4. Be sure electrical outlets and tools are properly grounded.
5. Use adequate light for the job at hand.
6. Make sure there is plenty of ventilation. Never operate the engine of the tractor in a closed building. The exhaust fumes may cause asphyxiation.
7. Before working on this machine, shut off the engine, set the brakes, and remove the ignition key.
8. Never work under equipment unless it is secured by a mechanical stand.
9. Use personal protection devices such as eye, hand and hearing protectors, when performing any service or maintenance work. Use heavy gloves when handling blades.
10. Only use genuine parts for service and maintenance.
11. A fire extinguisher and first aid kit should be kept readily accessible while performing maintenance on this equipment.
12. Periodically tighten all bolts, nuts and screws and check that all pins are properly installed to ensure unit is in a safe condition.
13. When completing a maintenance or service function, make sure all safety shields and devices are installed before placing machine in service.

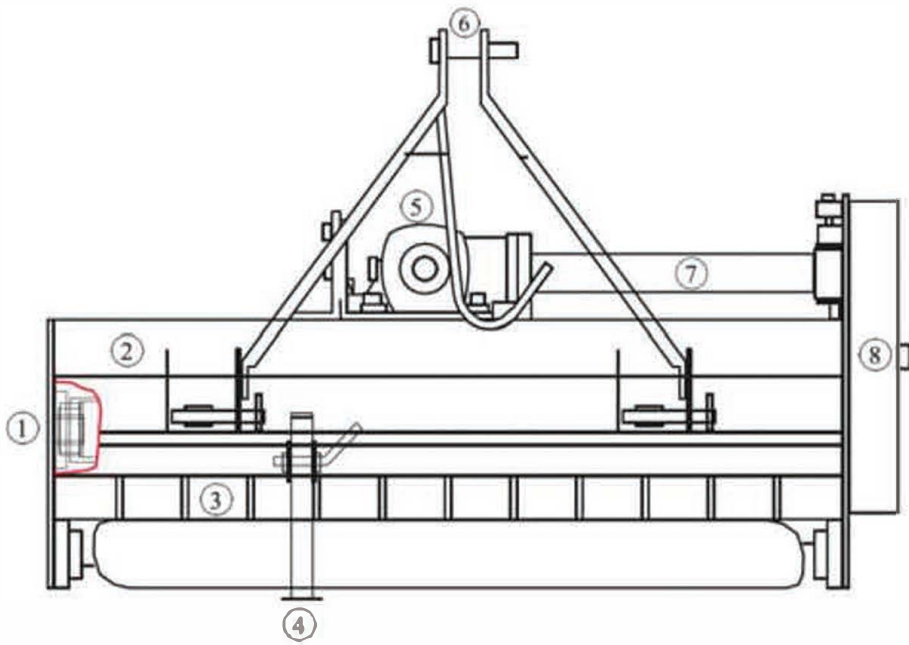

1.	Blade axle
2.	Blade axle cover
3.	Combined fender
4.	Stand
5.	Gear box
6.	Top Link Bracket
7.	Transmission shaft
8.	Belt & Pulley Cover

PTO Shaft

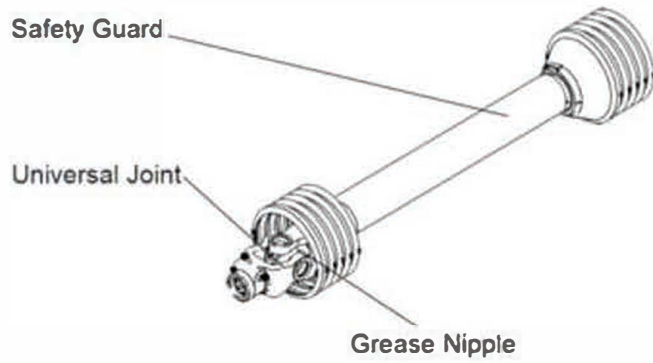

1.6 Safety & Model Decals

The position of safety decals is shown in the illustrations below. Good safety requires that you familiarize yourself with the various safety signs, and increase your SAFETY AWARENESS.

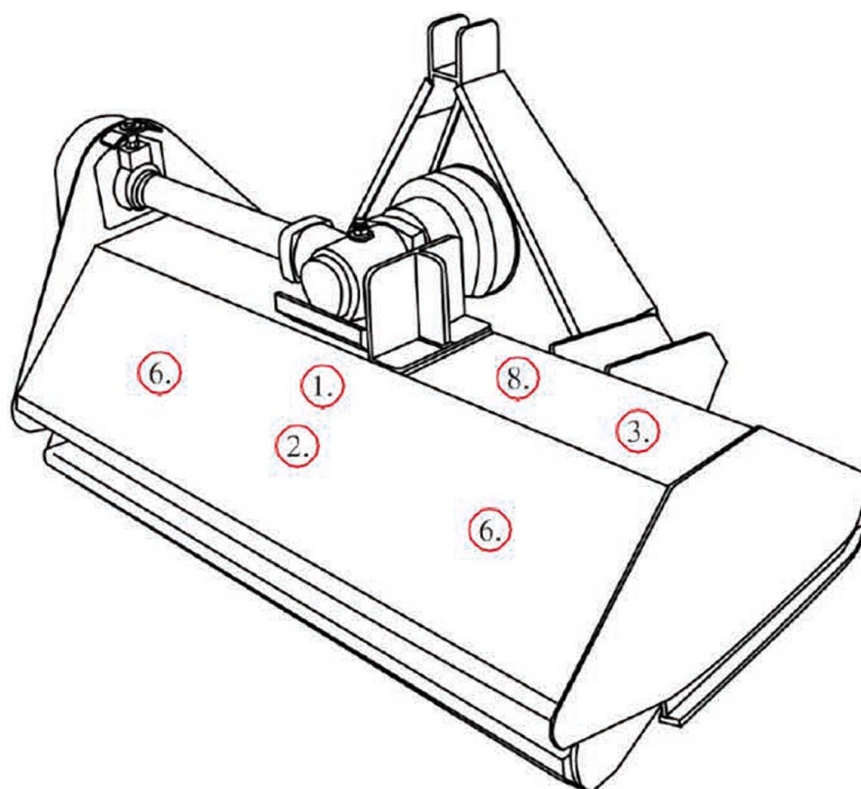
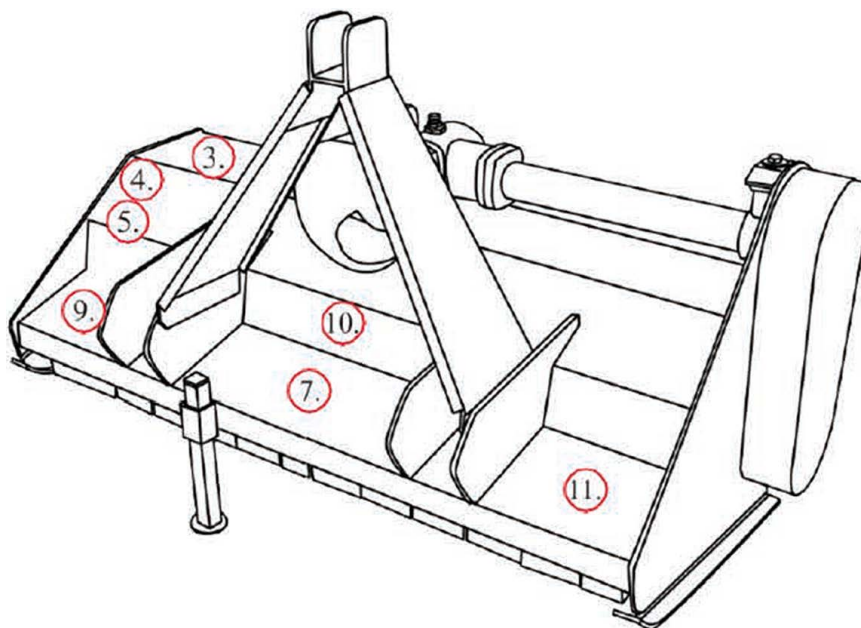



2. PRODUCT SPECIFICATIONS

2.1 Implement Specifications

Feature	Eco-Mow 1050	Eco-Mow 1250	Eco-Mow 1350H	Eco-Mow 1550	Eco-Mow 1550H
Dimensions	1200×790×850mm	1400×790×850mm	1500×790×850mm	1700×790×850mm	1700×790×850mm
Structure Weight	220kg	236kg	310kg	266kg	350kg
Cutting Width	1020mm	1220mm	1320mm	1520mm	1520mm
Cutting Height	0-100mm	0-100mm	0-100mm	0-100mm	0-100mm
Rotor Diameter	108mm	108mm	108mm	108mm	108mm
Hammer Flails	16	20	24	24	24
Y Blades	32	40	48	48	48
Belts	4	4	4	4	4
Power Required	18+hp	20+hp	20+hp	25+hp	25+hp
Hitch Type	Fixed	Fixed	Hydraulic Side Shift	Fixed	Hydraulic Side Shift
3 Point Linkage Cat	1 & 2	1 & 2	1 & 2	1 & 2	1 & 2
Gearbox Rating	55hp With Overrun Clutch	55hp With Overrun Clutch	55hp With Overrun Clutch	55hp With Overrun Clutch	55hp With Overrun Clutch
Rotor Bearings	SKF	SKF	SKF	SKF	SKF
Skid Width	60mm	60mm	60mm	60mm	60mm
PTO Shaft	Series 4 1000mm	Series 4 1000mm	Series 4 1000mm	Series 4 1000mm	Series 4 1000mm

Feature	Eco-Mow 1750	Eco-Mow 1750H	Eco-Mow 1950	Eco-Mow 1950H
Dimensions	1900×790×850mm	1900×790×850mm	2100×790×850mm	2100×790×850mm
Structure Weight	282kg	365kg	308kg	388kg
Cutting Width	1720mm	1720mm	1920mm	1920mm
Cutting Height	0-100mm	0-100mm	0-100mm	0-100mm
Rotor Diameter	108mm	108mm	108mm	108mm
Hammer Flails	28	28	30	32
Y Blades	56	56	60	64
Belts	4	4	4	4
Power Required	35+hp	35+hp	45+hp	45+hp
Hitch Type	Fixed	Hydraulic Side Shift	Fixed	Hydraulic Side Shift
3 Point Linkage Cat	1 & 2	1 & 2	1 & 2	1 & 2
Gearbox Rating	65hp With Overrun Clutch	65hp With Overrun Clutch	65hp With Overrun Clutch	65hp With Overrun Clutch
Rotor Bearings	SKF	SKF	SKF	SKF
Skid Width	60mm	60mm	60mm	60mm
PTO Shaft	Series 5 1000mm	Series 5 1000mm	Series 5 1000mm	Series 5 1000mm

USES

- Perfect for use after storms when debris is scattered throughout areas usually maintained with normal mowers
- Multi-purpose machines for mulching foliage and sticks
- Ideal for thick grass, sticks, undergrowth and light vine mulching
- Vegetable and pasture topping
- Roadside maintenance.

FEATURES

- Cutting height controlled by adjustable skids
- High strength mulching blades
- Belt driven
- Safety flaps to prevent debris being thrown
- Extra strong and designed with safety in mind
- Support leg for storage
- Solid hitch

2.2 Identification of the implement

An Identification plate is affixed to the frame of each implement. It contains the “CE” Certification brand and information about: the Manufacturer, Type, Serial Number, Weight and Year of Manufacture.

CE Identification Plate

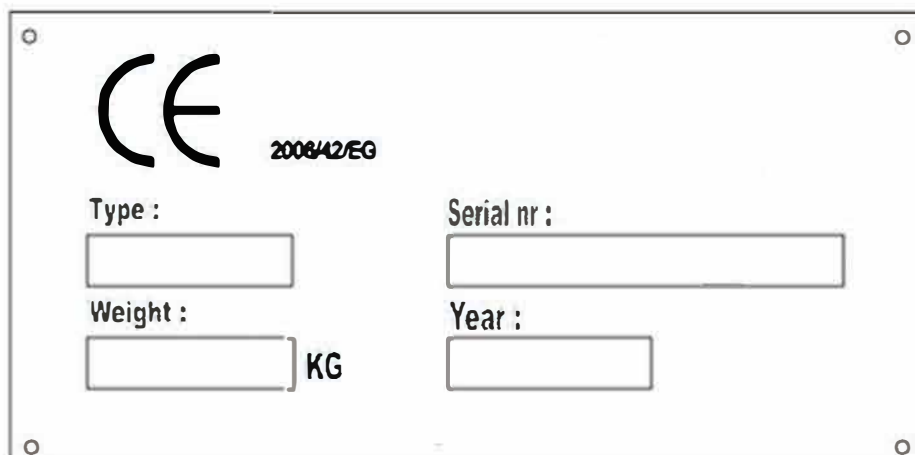

The diagram shows a rectangular identification plate with four corner mounting holes. In the top left corner, there is a large CE mark and the text "2008/42/EG". Below this, the plate is divided into four input fields:

Type :	Serial nr :
<input type="text"/>	<input type="text"/>
Weight :	Year :
<input type="text"/> KG	<input type="text"/>

3. OPERATION

3.1 Checking Before Operating

Before operating the machine, the following areas should be checked off:

1. Before starting up the machine, check and Lubricate all grease points, on the machine and drive shaft.
2. Use only an agricultural tractor with horsepower within limits of the implement.
3. Check that the machine is properly attached to the tractor. Be sure retainers are used on the mounting pins.
4. Be sure extra weights are mounted on the front of the tractor, if required.
5. Check the oil level in the gearbox. Add as required.
6. Check that the tractor PTO shaft turns freely and that the machine driving shaft can telescope easily.
7. Check the blades. Be sure they are not damaged or broken and swing freely in their mount. Repair or replace as required.
8. Check and tighten the blade bolts.
9. Check for entangled material in all rotating parts. Remove this material.
10. Install and secure all guards, doors and covers before starting.
11. Before installing the PTO. ensure the engine is stopped and the PTO shaft is in safe working order.
12. All other people shall leave the area before connecting the driving power from the tractor. Keep the output of the tractor at 540 RPM.
13. Before cleaning, repairing and lubricating the machine, stop the motor and take the key away with you.
14. When the PTO shaft is not connected with the tractor, support it through the frame to protect it from lying in the dirt.
15. Don't approach the machine when it is operating.

3.2 Adjustments

ADJUSTING THE HEIGHT

To get the most out of your flail mower, it should be set within the recommended height.

To save fuel and power, and reduce wear and tear, the cutting height must be regulated correctly.

When adjusting the working height, loosen screw (1), remove screw (2) on both sides; The roller height (see drawing) can be adjusted by aligning the selected hole in the roller support bracket at position 2. The lowest hole is the highest working height; put the screw (2) into the selected hole; tighten screw (1) and screw (2).

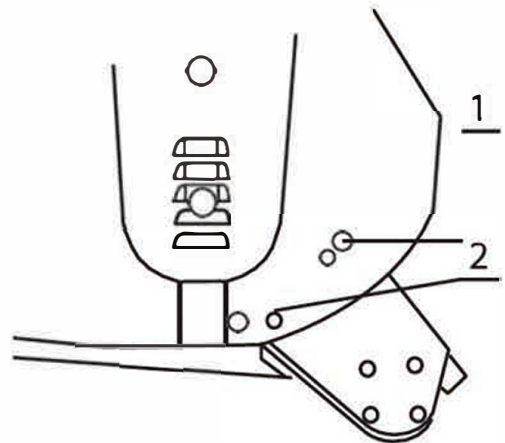

FLAIL MOWER ADJUSTMENT

1. On a flat piece of ground, attach the Flail mower to the tractor using the three point linkage.
2. Use a solid adjustable top link.
3. Lower the three point linkage to its lowest position.
4. With the roller at the rear in contact with the ground, adjust the length of the top link so that the lower edge at the side of the flail mower is parallel with the ground.
5. Rotate the blade drum by hand so that a row of blades hang vertically towards the ground.

6. Measure the clearance between the bottom of the extended blades and the ground.
Minimum 50mm
Note: In rough or lumpy paddocks, the clearance needs to be increased to ensure that the blades don't impact the ground in operation.
7. Adjust the roller height to increase or decrease the blade clearance as required.
8. Go through steps 4 to 7 until the required clearance is achieved.

When the Flail mower has been set up with the required tolerances: operate the Flail mower with tractor in low range and the PTO delivering 540 RPM.

3.3 Drive Belt Adjustment

1. Loosen the Screw A and B that locks the support shaft and loosen the counter nut C. Loosen the screws that lock the gear box on the mounting plate D.
2. Adjust the drive belt tension. The correct belt tension is achieved when the belt can be deflected by the belt thickness about 10mm at the center point between the pulleys.
3. Align the gearbox so the drive shaft is parallel with the body.
4. Use a straight edge to make sure the belt pulleys are in line and running true. If misaligned, call your dealer or service agent for technical support.
5. Fit the safety covers and tighten the mounting bolts before operation.

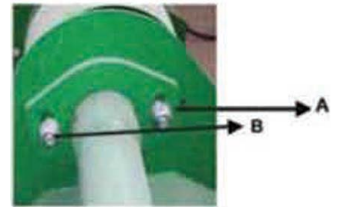

Approx 10mm deflection



Align with a straight edge

3.4 Starting Up

Before starting the machine, check and adjust the following items:

- Drive belt tension.
- Gearbox oil level.
- Grease nipples on bearings and PTO shaft.
- All bolts, nuts and screws.

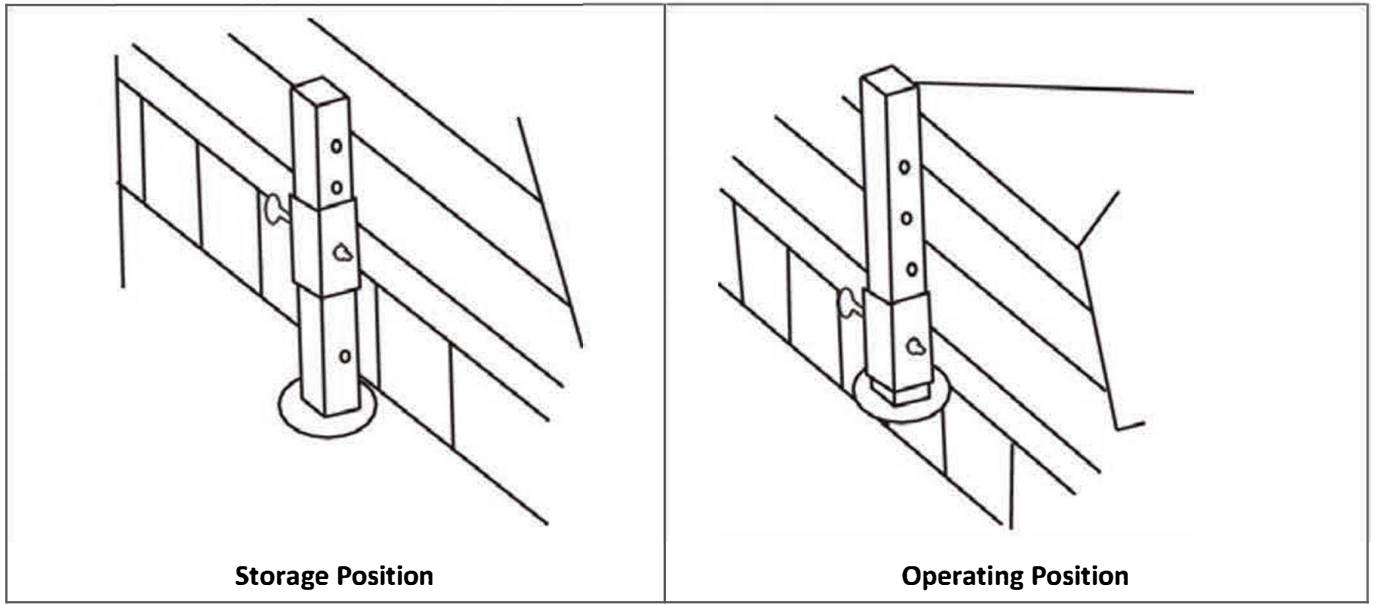

In order to keep the machine stable, lower the adjustment stand when the machine is stopped (see above drawing). Follow all safety precautions detailed in this manual.

The machine is equipped with a standard category one, three point linkage.

Back the tractor into position in front of the flail mower. Lower the tractor hydraulic lift arms. Turn the tractor off. Maneuver the implement by hand and attach the lower link arms to the lower link pin. Ensure they are secured with lynch pin. Attach the top link to the top link bracket. Adjust the lower link sway chains to allow minimal lateral movement. Attach the PTO shaft to the tractor PTO ensuring it has been cut to the required length.

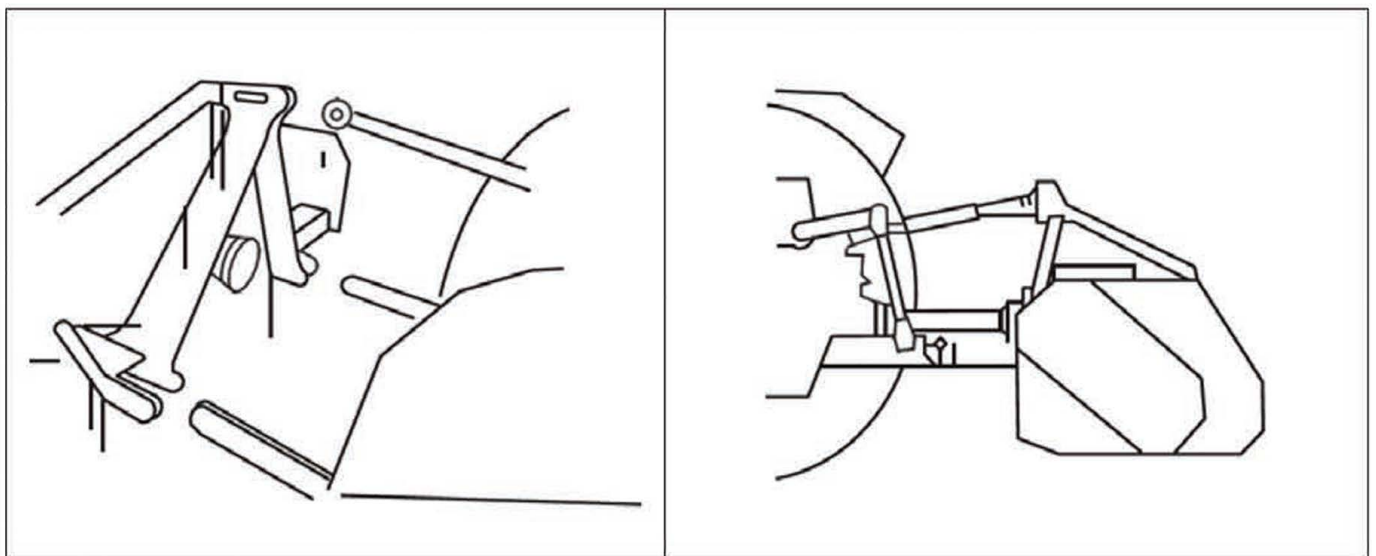

3.5 Hydraulic Connection

- Switch the engine off, set the handbrake and remove the ignition key. Push the hydraulic lever to release pressure at the remotes. Connect the implement's hydraulic hoses to the remotes using the quick couplers, having checked the quick couplers are clean and in good condition.
- Start the engine and activate the hydraulics to check the connection. Check there are no oil leaks at the connection or the implement.
- Before disconnecting, stop the engine and move the remotes lever back and forth to release the hydraulic oil pressure as previously mentioned.

3.6 Greasing and Lubrication

EACH 4 HOURS OF WORK

- Check and tighten nuts and bolts.
- Grease with lithium based grease when it is indicated by the symbol GREASE.

AFTER 50 HR OF WORK

Check and fill the gearbox to the required level, using oil type SAE 90 EP API GL4.

EACH 100 HR OF WORK

Check the gearbox oil level. Replace as required.



4. SERVICE AND MAINTENANCE

4.1 Service

FLUIDS AND LUBRICANTS

Grease: Use multi-purpose lithium based grease.

Gear Box Oil: Use SAE 90 Gear oil.

Storing Lubricants: Your machine can operate at top efficiency only if clean lubricants are used. Use clean containers to handle all lubricants. Store them in an area protected from dust, moisture and other contaminants.

GREASING

1. Use a hand-held grease gun for all greasing.
2. Wipe grease nipple with a clean cloth before greasing, to avoid injecting dirt and grit.
3. Replace broken nipples immediately.
4. If nipples will not take grease, remove and clean thoroughly. Also clean lubricant passageway. Replace nipple if necessary.

4.2 Maintenance

The period recommended is based on normal operating conditions. Severe or unusual conditions may require more frequent maintenance.

8 HOURS OR DAILY MAINTENANCE

1. Check all nuts and bolts, tighten as required.
2. Check the blade and blade bolts every day and replace the damaged parts. Don't install damaged, worn and unbalanced blade. Replace sleeves as they become worn.



NOTE

The operator should put on gloves and use suitable tools before changing blade.

3. Check the oil in gearbox. Fill up to line if necessary.
4. Pump grease into each grease nipple three to five times.
5. Clean the implement; remove grass and mud.

SEASON MAINTENANCE

1. Check the machine as in the terms of daily maintenance.
2. Check the oil in gearbox; replace it if it is contaminated.
3. Check the blade spindles for wear and tear. If worn, disassemble and clean them and replace them if it is necessary, grease as required.

ANNUAL MAINTENANCE

1. Thoroughly clean mud and grass off the machine.
2. Check and clean blade axles. Replace seals and grease as required.
3. Check all blades, replace them if they are worn-out or damaged.
4. Repair or replace the side skirts back to their original size and shape. Replace damaged or broken protective devices.

GEAR BOX MAINTENANCE

The oil should be drained out and replaced after the first 50 hours of operation. Then the oil should be changed every 250 hours, or at least once a year.

Drain oil from the gearbox thoroughly. Check and clean it. Fill with new gear oil up to the dedicated oil level.

The draining procedure is as follows: remove the draining bolt under the gear box, so that the oil drains off. After the oil is drained out, put the plug back and fill with gear oil up to the dedicated oil level.

	8hrs/Daily	50hrs/Weekly	Annually
Lubricate PTO Shaft	x	x	x
Lubricate caster wheels	x	x	x
Lubricate blade spindle	x	x	x
Check gear box oil level		x	x
Clean machine			x
Lubricate and clean PTO shaft cover			x

PTO SHAFT MAINTENANCE

The PTO shaft is designed to telescope to allow for dimensional changes as the machine goes through its operating range. A tubular guard encloses the driving components and is designed to turn relative to the driving components. The shaft should telescope easily and the guard turn freely on the shaft at all times. Annual disassembly, cleaning and lubrication is recommended to insure that all components function as intended. To maintain the shaft, follow this procedure:

1. Remove the shaft from the machine.
2. Pull shaft apart.
3. Use a screwdriver to pry the tabs out of the sleeves on each end.
4. Pull the shaft out of the plastic tubular guard.
5. Use a solvent to clean the male and female portions of the telescoping ends.
6. Apply a light coat of grease to each end.
7. Clean the grooves on each end where the tabs are located. Clean each tab also.
8. Apply a light coat of grease to each groove.
9. Insert the shaft into its respective guard and align the slots with the groove.
10. Insert the tabs through the slots and seat in the groove.
11. Check that each guard turns freely on the shaft.
12. Assemble the shaft.
13. Check that the shaft telescopes easily.
14. Replace any components that are damaged or worn.
15. Install the shaft on the machine.

GEAR BOX MAINTENANCE

The gearbox used on the Flail mower will give many years of trouble-free service with minimal maintenance requirements. Maintain the gearbox by following this procedure:

Oil Level

- Remove the level plug from the rear or side of the gearbox.
- Add oil through the filler plug located on top of gearbox until oil comes out of the level plug.
- Add through the level plug if required.
- If gearbox has a dipstick on filler plug, then fill to indicator mark.



NOTE

Check the oil level only when the unit is cold and the machine is on the level.

5. STORAGE

- Clean the machine inside and out so as to avoid corrosion.
- Don't spray water on the rolling bearing if you clean the machine with high pressure sprayer.
- Check and clean the universal joint, driving belt press roller, or replace them if they are not in good condition.
- Spread oil on all parts required.
- Recoat the parts rubbed and damaged for anti-corrosion.
- Store the machine in a dry, level area.

5.1 Operation After Storage

Before the machine is started up, check the following items regularly:

- Check oil level and add if required.
- Check and tighten all screws and nuts.
- Check the blade condition. Replace as required.
- Check the air hole on the gearbox. If it is blocked, clean or open the hole with compressed air.
- Don't spread oil or grease on the driving belts. If there is oil or grease on the belts, wipe the belts, to avoid slippage and premature wear.
- Check all moving parts and replace them if necessary.
- Check the protective covers are complete and operate correctly.

6. TROUBLESHOOTING

FAILURE	CAUSE	SOLUTION	LEVEL OF DANGER
Excessive vibration of the machine	Broken flails	Replace broken flails	Flails can be replaced by a competent operator. In the other cases, replacement must be done by specialised staff.
	Broken rotor support	Replace rotor support with original parts	
	Broken driving support shaft	Replace shaft support with original parts	
	The worst: bent rotor	Replace rotor with original parts	
The grass is not cut	Broken flails	Replace flails	For replacement of flails, adjustment or replacement belts and fixing lock joints, see paragraph relating to maintenance.
	Belt slipping	Adjust belt tension	
	Broken belts	Replace belts	
	Pulleys slipping on shafts	Fix pulley lock joints	
	Broken gear box	Repairing or replacement of gear box	
Clogging of hammers/knives	Rotor speed is too low	Increase rotor speed	
Excessive wear of hammers/knives	Rotor speed is too high	Decrease rotor speed	
Flail mower vibrates during works	Foreign matter stuck in between blades	Remove foreign matter	Secure flail mower on a mechanical stand before maintaining blades or rotor.
	Hammers/knives broken Bolts of the rotor shaft support have come loose	Replace hammer/knives Lock bolts	

7. PARTS LISTS

Eco-Mow Flail Mower Assembly

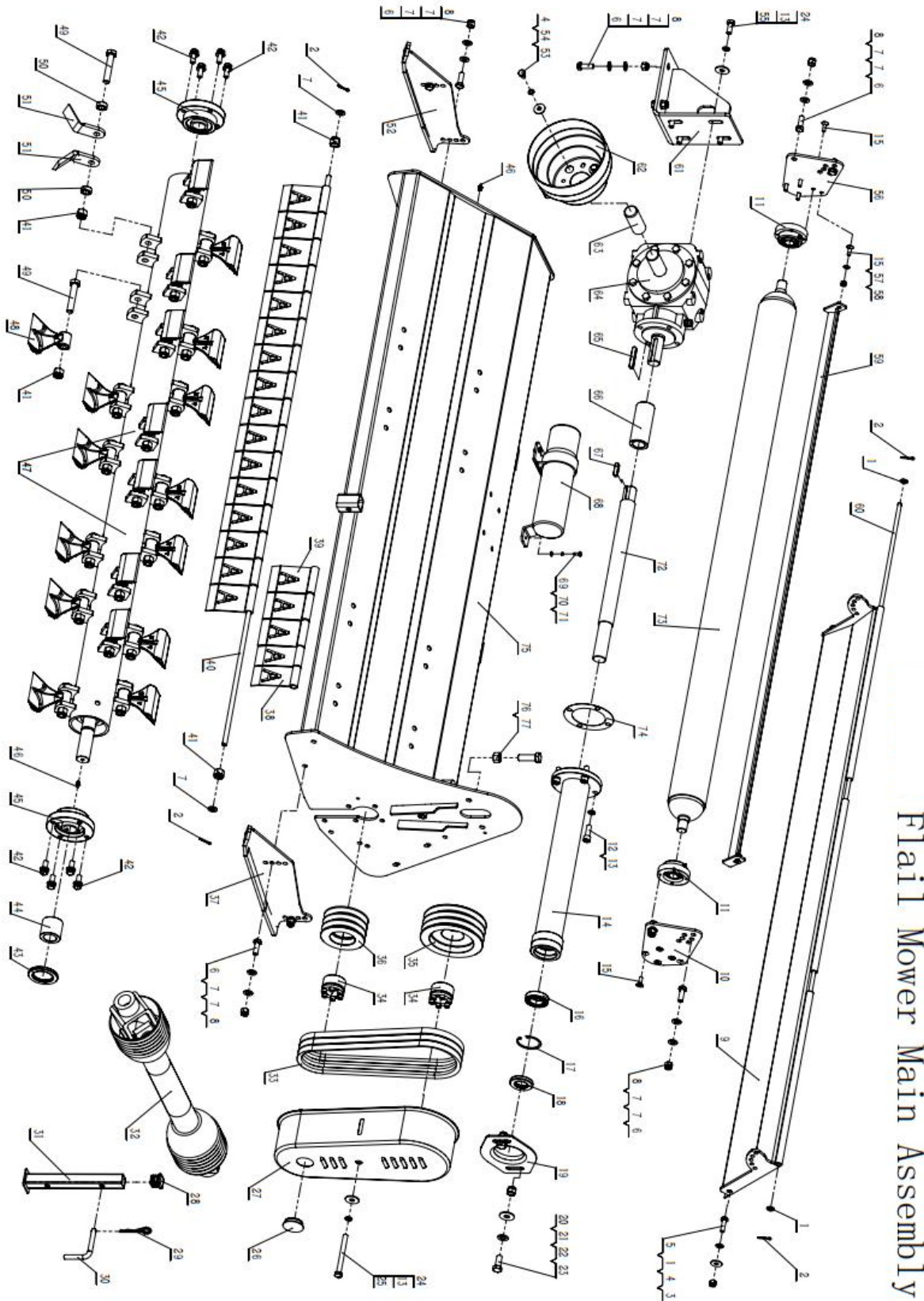

Flail Mower Main Assembly

Ser.No.	Part NO.	Name & Specifications	Quantity	Remark
1	GB/T 97.1-Ø10	Flat pad 10	4	
2	GB/T 91-4×25	Cotter Pin Type A 4×25	4	
3	GB/T 889.1-M10	Lock nut M10	2	
4	GB/T 96.1-Ø10	Large flat pad 10	6	
5	GB/T 5783-M10×35	Bolt M10×35	2	
6	GB/T 5783-M12×35	Bolt M12×35	12	
7	GB/T 97.1-Ø12	Flat pad 12	26	
8	GB/T 889.1-M12	Lock nut M12	12	
9	EFGC-A175.012	Rear cover plate welding parts	1	
10	EFGC175.111	Drum left connecting plate	1	
11	EFGC175.127	Insert spherical bearing UC205	2	
12	GB/T 70.1-M12×35	Hexagon socket head screw M12×35	4	
13	GB/T 93-Ø12	Spring pad 12	9	
14	EFGC125.015	Drive shaft tube welding parts	1	105-125
	EFGC155.015	Drive shaft tube welding parts	1	135-155
	EFGC175.015	Drive shaft tube welding parts	1	165-195
15	GB/T 70.3-M8×25	Hexagon socket countersunk head screw M8×25	10	
16	GB/T 276-6007-2RZ	Deep groove ball bearing 6007-2RZ	1	
17	GB/T 893.1-Ø62	Retaining rings for holes 62	1	
18	GB/T 13871.1-35×62×10	TC type oil seal 35×62×10	1	
19	EFGC175.101-1	Connection board	1	
20	GB/T 889.1-M14	Lock nut M14	2	
21	GB/T 96.1-Ø14	Large flat pad 14	2	
22	GB/T 97.1-Ø14	Flat pad 14	2	
23	GB/T 5783-M14×35	Bolt M14×35	2	
24	GB/T 96.1-Ø12	Large flat pad 12	5	
25	GB/T 5782-M12×120	Bolt M12×120	1	
26	FM120.111	Rubber cover	1	
27	EFGC175.014	Pulley cover welding parts	1	
28	EFGC175.122	Square tube plug	1	
29	EFGC175.130	R pin 3.5	1	
30	EFGC175.115	leg pin	1	
31	EFGC175.023	Leg welding parts	1	
32	T4S-Y6W-05-05-800	PTO 04B800	1	
33	GB/T 11544-BX(17)×1016	Belt BX (17)×1016	3	
34	EFGC175.131	Z3 type expansion sleeve 35×60	2	
35	EFGC175.106	big pulley	1	
36	EFGC175.107	small pulley	1	
37	EFGC175.019	Right pad welding part	1	
38	EFGC175.109	Baffle (optional)	n	
39	EFGC175.108	Baffle (universal)	N	
40	EFGC105.110	baffle shaft	1	105
	EFGC115.110	baffle shaft	1	115
	EFGC125.110	baffle shaft	1	125

	EFGC135.110	baffle shaft	1	135
	EFGC145.110	baffle shaft	1	145
	EFGC155.110	baffle shaft	1	155
	EFGC165.110	baffle shaft	1	165
	EFGC175.110	baffle shaft	1	175
	EFGC185.110	baffle shaft	1	185
	EFGC195.110	baffle shaft	1	195
41	GB/T 889.1-M16	Lock nut M16	N+2	
42	GB/T 9074.17-M12×30	Combination bolt M12×30	8	
43	GB/T 13871.1-55×80×8	TC type skeleton oil seal 55×80×8	1	
44	EFGC175.103	bushing	1	
45	EFGC175.128	Insert spherical bearing UC207	2	
46	JB/T 7940.1-M8×1	Oil cup M8×1	2	
47	EFGC105.013	Knife shaft welding parts	1	105
	EFGC115.013	Knife shaft welding parts	1	115
	EFGC125.013	Knife shaft welding parts	1	125
	EFGC135.013	Knife shaft welding parts	1	135
	EFGC145.013	Knife shaft welding parts	1	145
	EFGC155.013	Knife shaft welding parts	1	155
	EFGC165.013	Knife shaft welding parts	1	165
	EFGC175.013	Knife shaft welding parts	1	175
	EFGC185.013	Knife shaft welding parts	1	185
	EFGC195.013	Knife shaft welding parts	1	195
48	EFGC175.125	hoe blade	N	
49	GB/T 5782-M16×85	Bolt M16×85	N	10.9L
50	EFGC175.102	Blade spacer	2N	Option
51	EFGC175.121	Y blade	2N	
52	EFGC175.018	Left pad welding part	1	
53	GB/T 5783-M10×16	Bolt M10×16	4	
54	GB/T 93-Ø10	Spring pad 10	4	
55	GB/T 5783-M12×30	Bolt M12×30	4	
56	EFGC175.112	Roller right connecting plate	1	
57	GB/T 97.1-Ø8	Flat pad 8	2	
58	GB/T 889.1-M8	Lock nut M8	2	
59	EFGC105.016	Scraper welding parts	1	105
	EFGC115.016	Scraper welding parts	1	115
	EFGC125.016	Scraper welding parts	1	125
	EFGC135.016	Scraper welding parts	1	135
	EFGC145.016	Scraper welding parts	1	145
	EFGC155.016	Scraper welding parts	1	155
	EFGC165.016	Scraper welding parts	1	165
	EFGC175.016	Scraper welding parts	1	175
	EFGC185.016	Scraper welding parts	1	185
	EFGC195.016	Scraper welding parts	1	195
60	EF105.108	baffle shaft	1	105
	EF115.108	baffle shaft	1	115

	EF125.108	baffle shaft	1	125
	EF135.108	baffle shaft	1	135
	EF145.108	baffle shaft	1	145
	EF155.108	baffle shaft	1	155
	EF165.108	baffle shaft	1	165
	EF175.108	baffle shaft	1	175
	EF185.108	baffle shaft	1	185
	EF195.108	baffle shaft	1	195
61	EFGC175.025	Gearbox mounting plate welding parts	1	
62	EFGC175.123	PTO protective cover	1	
63	EFGC175.133	Spline shaft dust cover	1	
64	XH50.300Z.02W	Gearbox	1	
65	GB/T 1096-10×65	Ordinary flat key A type 10×65	1	
66	EFGC175.105	Bushing	1	
67	GB/T 1096-10×40	Flat key A 10×40	1	
68	EFGC175.132	Instruction tube	1	Option
69	GB/T 818-M6×16	Cross recessed pan head screw M6×16	3	
70	GB/T 93-Ø6	Spring pad 6	3	
71	GB/T 97.1-Ø6	Flat pad 6	3	
72	EFGC125.104	transmission shaft	1	105-125
	EFGC155.104	transmission shaft	1	135-155
	EFGC175.104	transmission shaft	1	165-195
73	EFGC105.012	Drum welding parts	1	105
	EFGC115.012	Drum welding parts	1	115
	EFGC125.012	Drum welding parts	1	125
	EFGC135.012	Drum welding parts	1	135
	EFGC145.012	Drum welding parts	1	145
	EFGC155.012	Drum welding parts	1	155
	EFGC165.012	Drum welding parts	1	165
	EFGC175.012	Drum welding parts	1	175
	EFGC185.012	Drum welding parts	1	185
	EFGC195.012	Drum welding parts	1	195
74	EFGC175.118	Paper Pad	1	
75	EFKM-A105.011	Hood welding parts	1	105
	EFKM-A115.011	Hood welding parts	1	115
	EFKM-A125.011	Hood welding parts	1	125
	EFKM-A135.011	Hood welding parts	1	135
	EFKM-A145.011	Hood welding parts	1	145
	EFKM-A155.011	Hood welding parts	1	155
	EFKM-A165.011	Hood welding parts	1	165
	EFKM-A175.011	Hood welding parts	1	175
	EFKM-A185.011	Hood welding parts	1	185
	EFKM-A195.011	Hood welding parts	1	195
76	GB/T 5786-M16×1.5×50	Bolt M16×1.5×50	1	
77	GB/T 6171-M16×1.5	Ordinary nut M16×1.5	1	

Flail Mower Lifting Assembly

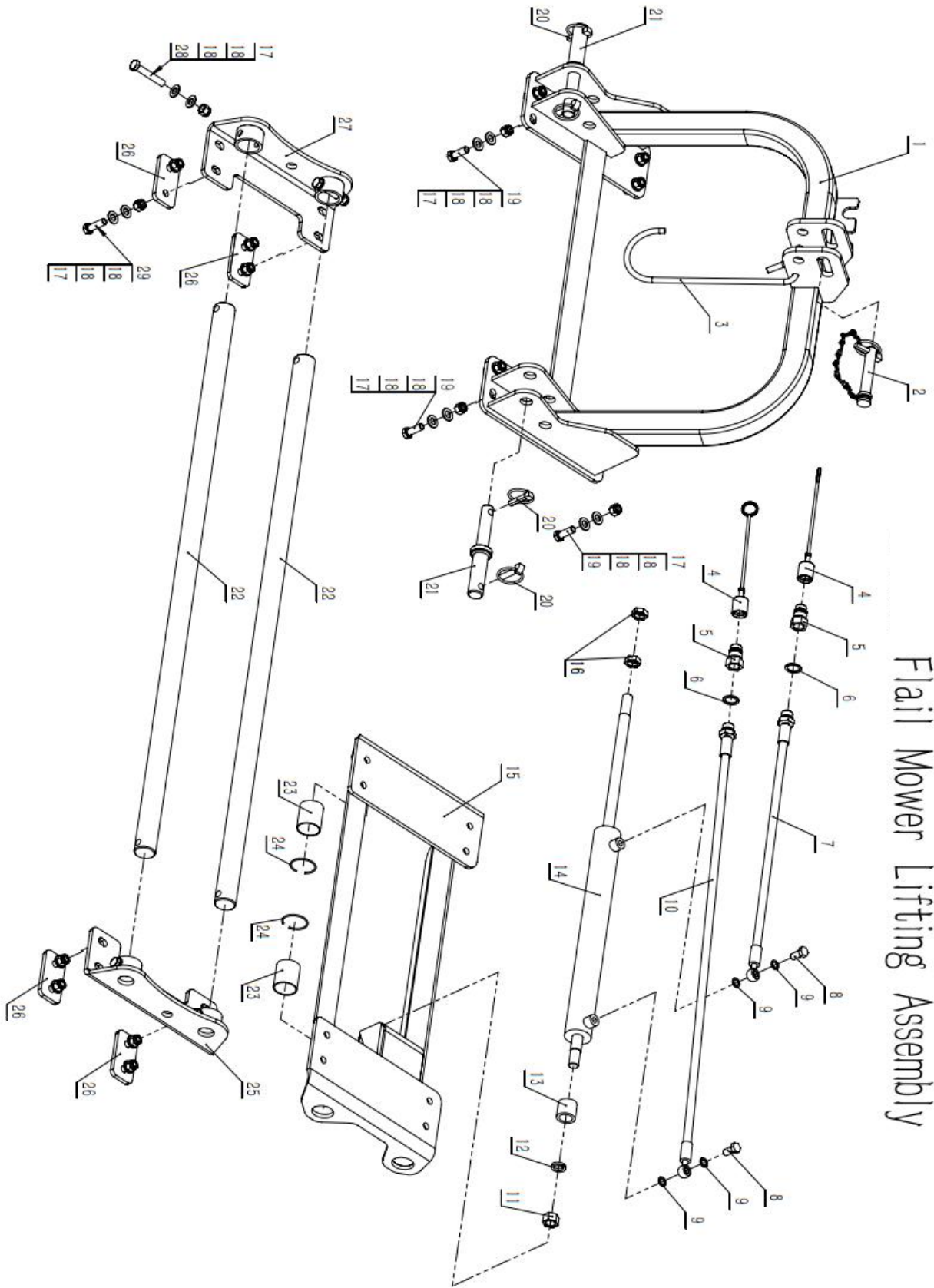

Ser.No.	Part No.	Name & Specification	Quantity
1	EFKM175.012	connection plate	1
2	EFGC175.116	Upper linakge pin	1
3	AGL125-111	Hook	1
4	AGF140.147	Dust cover	2
5	AGF140.146	Hose Quick connector G1/2	2
6	JB/T 982-G1/2	Bonded washer G1/2	2
7	EFGCH175.011-1	Hose 1500	1
8	EFGCH175.106	Air bolt	2
9	JB/T 982-Ø12	Bonded washer Ø12	4
10	EFGCH175.011-2	Hose 1900	1
11	GB/T 6171-M18×1.5	Plain nut M18×1.5	1
12	GB/T 93-Ø18	spring washer 18	1
13	EFGCH175.101	cylinder sleeve	1
14	EFGCH175.012	cylinder	1
15	EFKMH175.011	Suspension connection plate	1
16	GB/T 6173-M18×1.5	Plain thin nut M18×1.5	2
17	GB/T 889.1-M12	Lock nut M12	20
18	GB/T 97.1-Ø12	washer 12	40
19	GB/T 5783-M12×35	Bolt M12×35	8
20	EFGC175.129	Lock pin assembly	4
21	EFA160.103	Lower linkage pin	2
22	EFGCH-Q175.104	slide pipe	2
23	SF-2 4050	Self-lubricating bearing 40×44×50	4
24	GB/T895.1-Ø45	Round wire snap rings for hole 45	4
25	EFKMH175.013	Right Support plate	1
26	EFKM175.101	Lining board	4
27	EFKMH175.012	Left Support plate	1
28	GB/T 5782-M12×70	Bolt M12×70	4
29	GB/T 5783-M12×40	Bolt M12×40	8

The information contained in this operations manual is a general introduction only. The information contained herein may be modified at any time, for any reason. Modification may affect the details or specifications of the product described in this manual. Therefore, users – dealers must include the manufacturing date and serial number when placing an order for spare parts and components. Thanks.

August 2024