



LandMax
Suppliers Of Quality Agricultural Machinery

21 Plummers Point Road, Tauranga



Flail Mower

AGH

Operator's Manual

FOREWORD

The purpose of this manual is to assist you in operating and maintaining your Flail mower. Read it carefully before operating and maintaining the Flail mower, it furnishes the specifications, construction, instructions and also the maintenance. Some information may be general in nature due to unknown and varying conditions. However, through experience and these instructions, you should be able to develop operating procedures suitable to your particular situation.

“Right” and “left” as used throughout this manual are determined by facing the direction the machine will travel when in use.

Please kindly note that the contents of this operations manual may be a little bit different from the Flail mower that you actually purchase. This is due to the continuous improvement and development of the flail mower however, the specifications and structure of the Flail mower shall be subject to change without notice.

We strive to make this operations manual as correct as possible. However, we do not guarantee the accuracy or recentness of the information herein, and we assume no liability for errors or omission.

CONTENTS

| | |
|---|----|
| CHAPTER I SAFETY INFORMATION..... | 3 |
| 1.1 Safety First | 3 |
| 1.2 Safety Signs | 4 |
| CHAPTER II SPECIFICATIONS | 5 |
| 2.1 Brief Introduction..... | 5 |
| 2.2 Specifications and Parameters for Flail Mower | 5 |
| CHAPTER III OPERATION..... | 6 |
| 3.1 Checking Before Operating | 6 |
| 3.2 Adjusting the Height..... | 6 |
| 3.3 Regulating the Tension of Driving Belt | 7 |
| 3.4 Starting up | 7 |
| CHAPTER IV SERVICE AND MAINTENANCE..... | 9 |
| 4.1 Service..... | 9 |
| 4.2 Maintenance | 9 |
| 4.3 Storage | 10 |
| 4.4 Operation After Storage | 11 |
| CHAPTER V ILLUSTRATED PARTS CATALOGUE | 12 |
| 5.1 The Frame Assembly | 13 |
| 5.2 The Sway Frame Assembly | 16 |
| 5.3 Blade Axle Subassembly | 19 |

CHAPTER I SAFETY INFORMATION

PLEASE NOTE

Make sure all potential operators of this equipment review this manual and all safety messages contained within.

1.1 Safety First

Read this service manual before using the machine.



This safety alert symbol indicates important safety messages in this manual. When you see this symbol, carefully read this message that follows and be alert to the possibility of personal injury or death.

This machine is designed for cutting grass and bush, and shall be used in the indicated purpose. You take the responsibility if the machine is used in any other purposes.

For safety of personnel and good performance of the machine, you shall check the performance of the machine and the tractor before starting the machine.

All persons and animals shall keep away the machine when you start it.

The operator shall not put on too loose clothes during operating the machine.

Do not touch the rotor when the machine rotates.

Keep away the machine when it moves.

When the tractor and the machine are moving on the road, always keep the machine off.

Before repairing the machine, stop all movable parts and the tractor, keep the key with yourself.

Always keep the machine in a good state, if necessary, repair or change the defective parts.

Don't use the machine to transport personnel.

Don't modify the machine.

Pay attention to the sharp and pointed parts during repairing the machine.

All protective parts shall be guaranteed to be in good state before starting the machine.

Don't leave the tractor when moving the machine; and always take away the key of the tractor with you.

The machine shall be operated in the recommended speed.

Don't stay between the tractor and the machine.

Don't start the machine in a closed place (due to the smoke from the tractor).

1.2 Safety Signs

1.2.1 Care of Safety Signs

1. Keep safety signs clean and legible at all times.
2. Replace safety signs that are missing or have become illegible.
3. If a component with a safety sign(s) affixed is replaced with a new part, make sure new safety sign(s) are attached in the same locations as the replaced components.
4. Safety signs are available from your authorized Distributor or Dealer Parts Department or the factory.

1.2.2 Safety Signs locations

The types of safety signs and locations on the equipment are shown in the illustrations that follow. Good safety requires that you familiarize yourself with the various safety signs, the type of warning and the area, or particular function related to that area, that requires your **SAFETY AWARENESS**.

CHAPTER II SPECIFICATIONS

2.1 Brief Introduction

Bush cutter is designed for pulverizing grass and short bramble, and shall be used in the indicated purpose.

The Flail mower consists of a rotating shaft with many blades attached to it. The blades cut the grass while traveling over the working area. Rotational power to the shaft is provided by the tractor PTO through the gearbox in the center of the machine.

The Flail mower attaches to the 3 point hitch on the tractor.

2.2 Specifications and Parameters for bush cutter

| | |
|--------------------|-----------------------------|
| MODEL | AGH-140 |
| DIMENSIONS (L×W×H) | 1850×1800×1020mm |
| STRUCTURE WEIGHT | 575Kg |
| CUTTING WIDTH | 1400mm |
| WORKING EFFICIENCY | 4600-12400m ² /h |
| PTO TURNING SPEED | 540RPM |
| PTO shaft | 05B-1800mm |
| POWER REQUIRED | 40-85HP |

CHAPTER III OPERATION



CAUTION: Be familiar with the machine before starting. Read this manual carefully to learn how to operate the machine safely and how to set it to provide maximum field efficiency.

3.1 Checking Before Operating



ATTENTION: Only use universal joint conforming to CE standard and protect them properly.

Before operating the machine, the following areas should be checked off:

1. **Pay attention to the warning stickers on each greasing point. Before starting the machine, please make sure lubricate each grease point with grease or oil according to requirement on the warning stickers.**
2. Use only an agricultural tractor of horsepower within limits of the machine specified.
3. Check that the machine is properly attached to the tractor. Be sure retainers are used on the mounting pins.
4. Be sure extra weights are mounted on the front of the tractor.
5. Check the oil level in the gearbox. Add as required.
6. Check that the tractor PTO shaft turns freely and that the machine driving shaft can telescope easily.
7. Check the blades. Be sure they are not damaged or broken and swing freely in their mount. Repair or replace as required.
8. Check and tighten the blade bolts.
9. Check for entangled material in all rotating parts. Remove this material.
10. Install and secure all guards, doors and covers before starting.
11. Before installing the universal joint, the tractor and the machine motor shall be stopped and the key be taken away. The universal joints shall be installed in good state, with proper protective parts.
12. The chain on the protective parts of the universal joint shall be guaranteed in good condition, in case, automatic rotation occurs.
13. All other persons shall leave the ground before connecting the driving power from the tractor. Keep the output of the tractor at 540 RPM.
14. Before cleaning, repairing and lubricating the machine, stop the motor and take away the key with you.
15. When the universal joint is not connected with the tractor, they must be connected again through the frame to protect the joint from damaging.
16. Don't approach the machine when the machine runs.

3.2 Adjusting the Height

In order to conduct a precise work, the machine shall be operated according to the recommended cutting height.

For saving fuel and power, and reducing the wear of the machine, the cutting height must be

regulated correctly.

When regulating the working height, loosen the screw (1), remove the screws (2) on both sides; regulate the roller height (see following drawing); fix the parts on the set position. The lowest hole is the highest working height; put the screws (2) into the set hole; tighten screw (1) and screws (2).

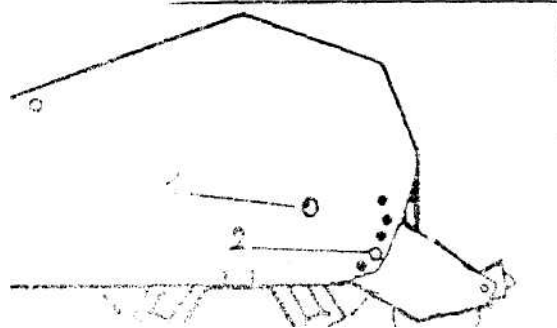

3.3 Regulating the Tension of Driving Belt



ATTENTION: The machine shall always stand still for regulating the tension.

Remove the driving belt cover, Loosen screws

Tighten the driving belt with screw, Tighten the screws

Put back the driving belt cover.

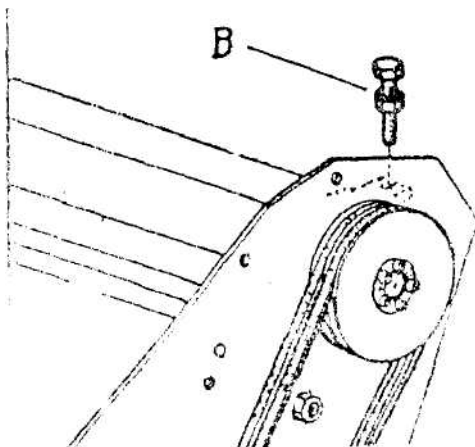

The recommended moving forward speed is 1.5 km/h, according to the grass height, thickness and working condition.

The driving belts are tightened by hand at the regulating point B up to the correct tension. Tighten all screws after regulating.

The driving belts shall be replaced when they are not in a good condition.

3.4 Starting up

Before starting the machine, control and adjust the following items:

- Tension of trapezoidal driving belt.
- Oil level of gear.
- Point of lubrication
- All bolts, nuts and screws.

In order to keep the machine stable, install the supporting frame on the machine when the machine is stopped (see above drawing).



ATTENTION: When transferring the moving state of the machine to the working state, do not stand between the machine and the tractor.

The machine coupling is equipped with 3 pins so that the machine can be coupled with all tractors with universal coupling with 3 pins. Each telescopic pole on the machine can be adjusted properly according to the type of the tractor. Keep the Flail mower away the tractor with a certain distance. The universal joint shall be tense and the largest distance in the closed state shall be 5/10 cm.

Moving the lifting arm, and putting it between axes, insert the joint pins and fix them with pins. Fix the lifting arm with chain and tensioning device so as to prevent lateral movement of the machine. Connect the universal joint to the PTO shaft of the tractor on the side of the tractor. In any event, it cannot produce a collision in any position. While connecting 3 points, pay attention to that the PTO shaft of the tractor shall be parallel with the ground. It is very important to keep the machine driving axle and the PTO shaft of the tractor in parallel.

The machine shall be lifted from the ground before moving the machine.

CHAPTER IV SERVICE AND MAINTENANCE

4.1 Service

4.1.1 FLUIDS AND LUBRICANTS

1. Grease:

Use multi-purpose lithium based grease.

2. Gear Box Oil:

Use N46 drive & hydraulic dual-purpose oil or equivalent for all operating conditions.

Each Gearbox Capacity: 0.85 liter

3. Storing Lubricants:

Your machine can operate at top efficiency only if clean lubricants are used. Use clean containers to handle all lubricants. Store them in an area protected from dust, moisture and other contaminants.

4.1.2 GREASING

- Use a hand-held grease gun for all greasing.
- Wipe grease nipple with a clean cloth before greasing, to avoid injecting dirt and grit.
- Replace and repair broken nipple immediately.
- If nipples will not take grease, remove and clean thoroughly. Also clean lubricant passageway. Replace nipple if necessary.

4.2 Maintenance



ATTENTION: All maintenance, repairing, cleaning and lubricating shall be conducted when the tractor and motor are stopped and the key is taken away.

By following a careful service and maintenance program for your machine, you will enjoy many years of trouble-free operation.

The period recommended is based on normal operating conditions. Severe or unusual conditions may require more frequent maintenance.

4.2.1 8 HOURS OR DAILY MAINTENANCE

- Check and screw all nuts and bolts in connection parts.
- Check the blade and fixing parts every day and replace the damaged parts if they are found damaged. Don't install damaged, worn and unbalanced blade. New sleeve shall be used to replace the worn fixing parts on the blade.

NOTE:

The operator shall put on gloves and use suitable tools before changing blade.

- Check the oil in gearbox. Fill them up to line if it's necessary.
- Press butter in each oil nipple three to five times.
- Clean the implement; take away all grass and mud.



IMPORTANT: Check the oil level only when the unit is cold and the machine is on the level.

4.2.2 SEASON MAINTENANCE

- Check the machine as below beside the terms of daily maintenance.
- Check the oil in gearbox; replace it if it is bad.
- Check the bearings of blade spindles whether mud and water have been enter because oil seals are damaged, if it's so, disassemble and clean them and replace them if it is necessary. And then press butter into them.
- Check the distance between bearings and gears. Adjust them if it's necessary.

4.2.3 ANNUAL MAINTENANCE

- Cleaning mud and grass on the machine thoroughly.
- Check all clearance between bearings and gears if you have replaced them. Please run it without load for 3-5 minutes.
- Check and clean blade axles. Replace oil seals and press butter into them.
- Check all blades, replace then if they are wear-out or damaged.
- Repair the side skirts; let them to original technical condition. Replace damaged or broken protective devices.
- Remove the driving shaft from the machine. Pull the machine driving shaft apart. Check and replace any components that are damaged or worn. Install the driveline on the machine. The machine driving shaft should telescope easily and the guard turn freely on the shaft
- Let the oil in gearbox drain out thoroughly. Check and clean it. Fill new gear oil up to the dedicated oil level.

The oil shall be drained off after 50 hours of using time. Then the oil shall be drained off every 250 hours. One time every year at least.

The draining procedure is as follows: remove the draining bolt under the gear box, so that the oil drains off. After the oil is drained off, put back the cover and fill the gear oil up to the dedicated oil level.



ATTENTION: Don't forget to disconnect the generator cable and batteries when welding on the machine, while the machine is coupled with the tractor.

4.3 Storage

The machine inside and outside shall be cleaned carefully so as to avoid corrosion.

Don't spray water on the rolling bearing if you clean the machine with high pressure sprayer.

Check and clean the universal joint, driving belt press roller, or replace them if they are not in good state.

Spread oil on all parts required.

Re-coat the parts rubbed and damaged for anti corrosion.

Store the machine in a dry, level area. Support the frame with planks if require.

4.4 Operation After Storage

Before the machine is started up, check the following items regularly:

Check oil level and add it if not enough.

Check and tighten all screws and nuts;

Check the regulated state of the machine.

Check the blade state.

Check the air hole on the gearbox. If it is blocked, clean or open the hole with compressed air.

Don't spread oil or grease on the driving belts. If there is oil or grease on the belts, wipe the belts, in case the belt sliding and wearing occur.



ATTENTION: Check the machine every 10 hours. Repair the damaged parts or replace the blade according to the manufacturer's recommendation, to keep the machine balancing.

Check all tightening parts and replace them if necessary.

Don't remove the protective parts on some points and protect the machine.



ATTENTION: In the case of vibration, stop the machine and check the blade. If the blade breaks or is damaged, replace it with same type of the blade. If the machine vibrates still, send the machine to the authorized repairer.

CHAPTER V ILLUSTRATED PARTS CATALOGUE

The manual contains a parts list for your machine. It is divided into major sections, which correspond to the groups shown in the Table of Contents and the accompanying illustration.

The first page of each major section lists the contents of that section, each of which consists of exploded views and related tabular listings.

When ordering parts

Always give your dealer the Model of your machine to assist him in ordering and obtaining the correct parts. Use the exploded view and tabular listing of the area of interest to exactly identify the required part.

5.1 The Frame Assembly

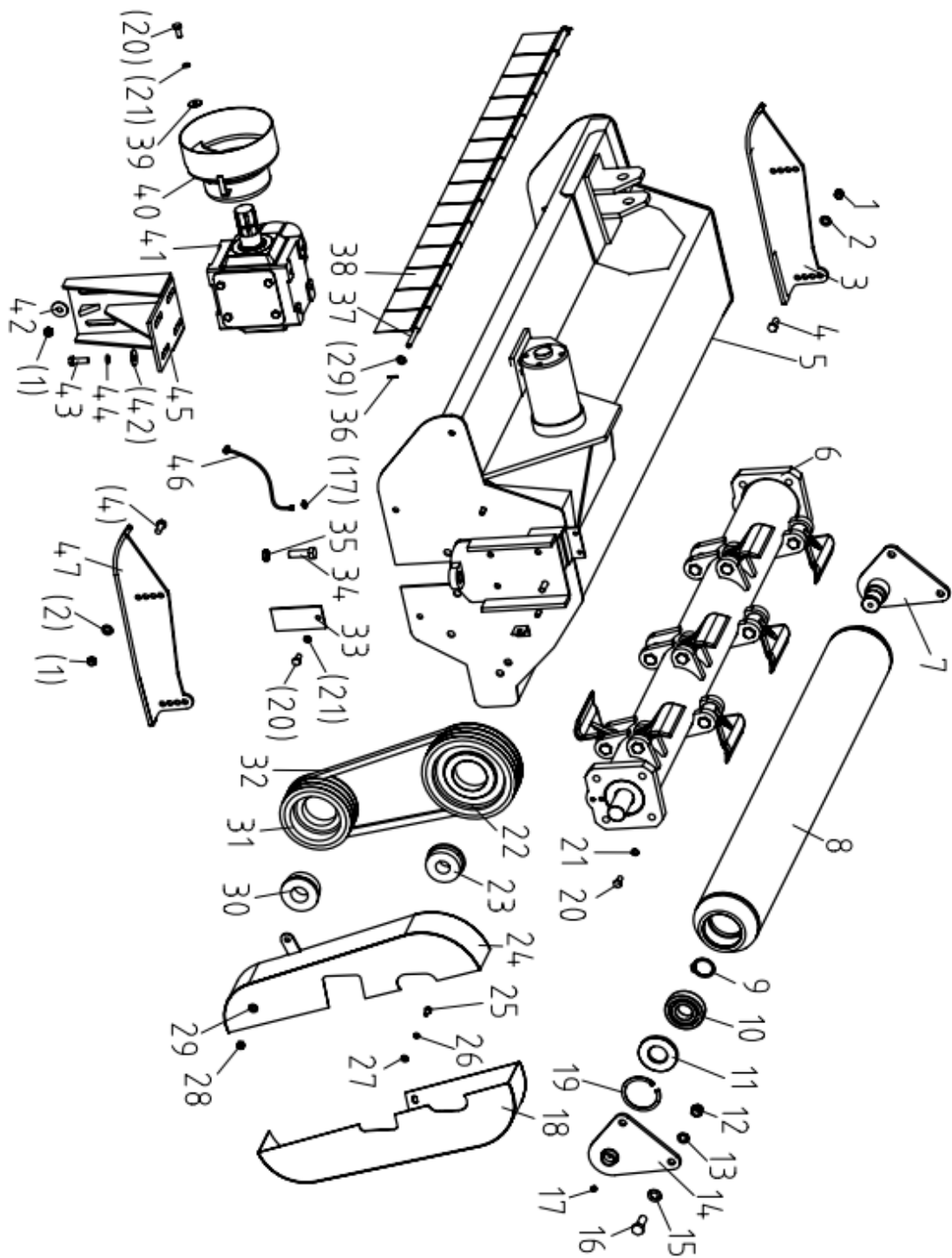

The Frame Assembly

The Frame Assembly

| NO. | Part NO. | Name & Specifications | Quantity | Remark |
|-----|--------------|------------------------------|----------|--------|
| 1 | GB6184-86 | Locking nut M12 | 8 | |
| 2 | GB97.1-85 | Plain washer 12 | 4 | |
| 3 | EFGC120.013 | Base plate (L) | 1 | |
| 4 | GB5783-86 | Bolt M12X30 | 4 | |
| 5 | EFAGF140.015 | The cover weldment | 1 | |
| 6 | | Blade axle subassembly | 1 | |
| 7 | EFAG140.020 | Supporting for roller (L) | 1 | |
| 8 | EFAG140.017 | Roller weldment | 1 | |
| 9 | GB894.1-86 | Circlip 40 | 2 | |
| 10 | GB/T276-94 | Bearing 6308 | 2 | |
| 11 | GB13871-94 | Oil seal 40X90X10 | 3 | |
| 12 | GB6184-86 | Locking nut M16 | 16 | |
| 13 | GB93-87 | Spring washer 16 | 4 | |
| 14 | EFAG140.022 | Supporting for roller (R) | 1 | |
| 15 | GB97.1-85 | Plain washer 16 | 4 | |
| 16 | GB5783-86 | Bolt M16X45 | 4 | |
| 17 | GB1152-89 | Oil cup M10X1 | 9 | |
| 18 | EFAGF140.014 | Belt cover (R) | 1 | |
| 19 | GB893.1-86 | Circlip 90 | 4 | |
| 20 | GB5783-86 | Bolt M10X25 | 8 | |
| 21 | GB93-87 | Spring washer 10 | 8 | |
| 22 | EFAG140.109 | Big belt ptiley | 1 | |
| 23 | JB/T7934Z3 | Swellable sleeve | 1 | |
| 24 | EFAGF140.013 | Belt cover (L) | 1 | |
| 25 | GB5783-86 | Bolt M8X20 | 2 | |
| 26 | GB93-87 | Spring washer 8 | 2 | |
| 27 | GB97.1-85 | Plain washer 8 | 2 | |
| 28 | GB6184-86 | Locking nut M10 | 2 | |
| 29 | GB97.1-85 | Plain washer 10 | 21 | |
| 30 | JB/T7934Z3 | Swellable sleeve | 1 | |
| 31 | EFAG140.107 | Small belt ptiley | 1 | |
| 32 | GB/T1154-97 | Strap B53 | 3 | |
| 33 | EFAG140.106 | Fender | 1 | |
| 34 | GB5783-86 | Bolt M16X1.5X50 | 1 | |
| 35 | GB6173-86 | Nut M16x1.5 | 1 | |
| 36 | GB879-86 | Elastic cylindrical pin 4x22 | 2 | |
| 37 | EFAG140.101 | Shaft for fender | 1 | |
| 38 | EF100.00.122 | Fender (W) | 14 | |
| 39 | GB96-85 | Plain washer 10 | 4 | |
| 40 | EF100.00.112 | Guard shade | 1 | |

| | | | |
|----|--------------|----------------------------------|----|
| 41 | XH50.003Z.03 | Gear box assembly | 1 |
| 42 | GB96-85 | Plain washer 12 | 10 |
| 43 | GB5783-86 | Bolt M12X35 | 4 |
| 44 | GB93-87 | Spring washer 12 | 4 |
| 45 | EFAGF140.026 | Adjusting frame for the gear box | 1 |
| 46 | | Union elbow M10X1 | 1 |
| 47 | EFGC120.014 | Base plate (R) | 1 |

5.2 The Sway Frame Assembly

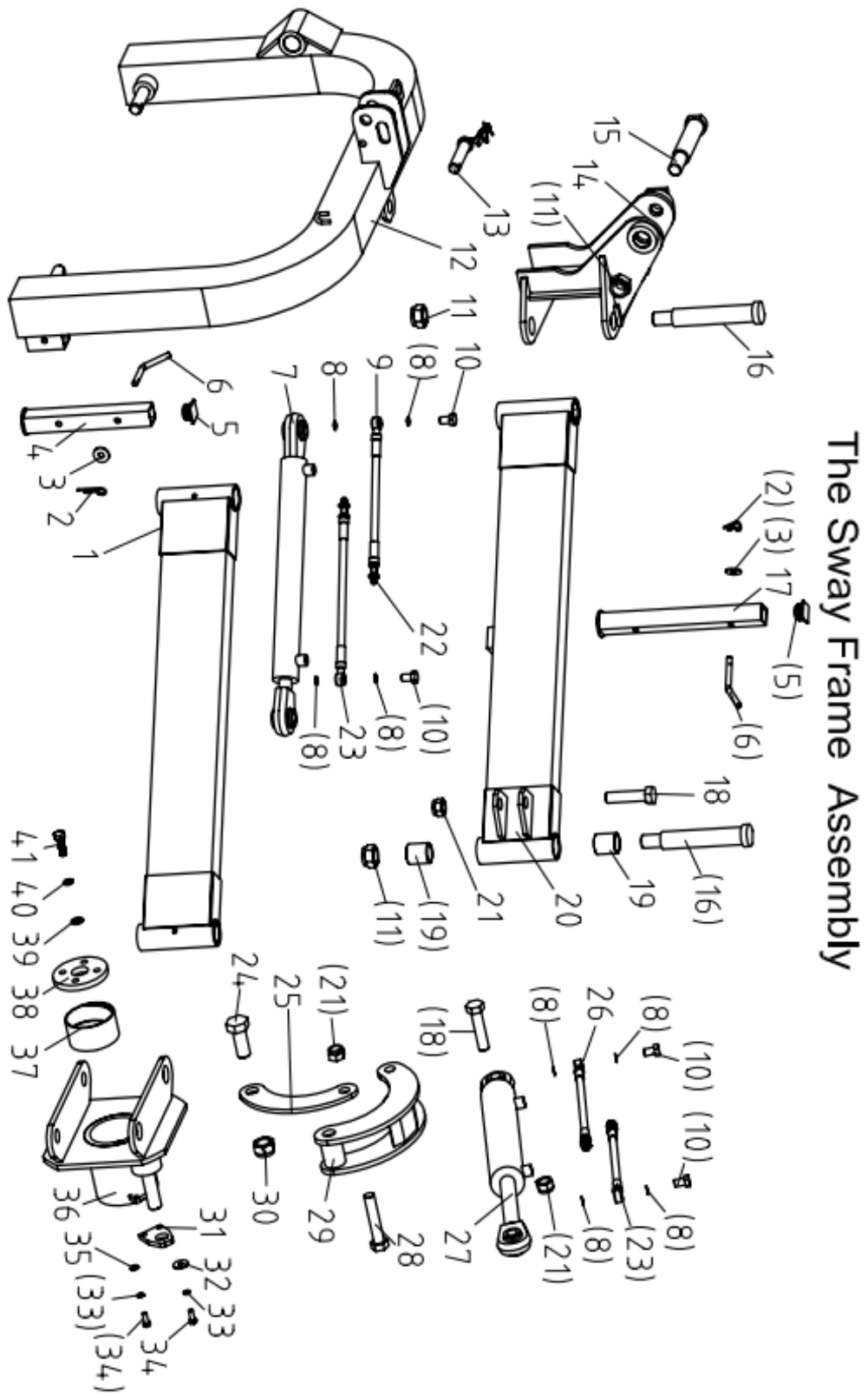

The Sway Frame Assembly

| NO. | Part NO. | Name & Specifications | Quantity | Remark |
|-----|---------------|----------------------------|----------|--------|
| 1 | EFAGF140.018 | Front swinging arm | 1 | |
| 2 | | R pin | 2 | |
| 3 | GB96-85 | Plain washer 12 | 10 | |
| 4 | EFAGF140.011 | Supporting frame (S) | 1 | |
| 5 | MFP120.00.101 | Cover (B) | 2 | |
| 6 | EF100.00.111 | Bent pin | 2 | |
| 7 | EFAGF140.021 | Parallel movement cylinder | 1 | |
| 8 | GB3451-86 | Washer 16 | 8 | |
| 9 | EFAGF140.020 | Oil pipe (S) | 1 | |
| 10 | GB3451-83 | Bolt M16X1.5 | 4 | |
| 11 | GB6184-86 | Locking nut M30X2 | 5 | |
| 12 | EFAGF140.016 | Hanging weldment | 1 | |
| 13 | 1G-180.00.019 | Pin shaft | 1 | |
| 14 | EFAGF140.017 | Sway seat | 1 | |
| 15 | EFAGF140.106 | Pin (S) | 1 | |
| 16 | EFAGF140.101 | Pin (L) | 4 | |
| 17 | EFAGF140.012 | Supporting frame (L) | 1 | |
| 18 | GB5781-86 | Bolt M24X100 | 3 | |
| 19 | EFAG140.105 | Bushing | 8 | |
| 20 | EFAGF140.019 | Rear swinging arm | 1 | |
| 21 | GB6184-86 | Locking nut M24 | 4 | |
| 22 | | Quick connector R1/2" | 4 | |
| 23 | EFAGF140.022 | Oil pipe | 2 | |
| 24 | GB5783-86 | Bolt M30X70 | 1 | |
| 25 | EFAGF140.107 | Push pedal | 1 | |
| 26 | EFAGF140.023 | Oil pipe (L) | 1 | |
| 27 | EFAGF140.024 | Side sway cylinder | 1 | |
| 28 | GB5781-86 | Bolt M24X120 | 1 | |
| 29 | EFAGF140.027 | The moon plate | 1 | |
| 30 | GB6184-86 | Locking nut M30 | 1 | |
| 31 | EFAGF140.102 | Clamping block | 1 | |
| 32 | EFAGF140.103 | Washer | 1 | |
| 33 | GB93-87 | Spring washer 10 | 8 | |
| 34 | GB5783-86 | Bolt M10X25 | 8 | |
| 35 | GB97.1-85 | Plain washer 10 | 21 | |
| 36 | EFAGF140.025 | Rotating shaft | 1 | |
| 37 | EFAGF140.104 | Bushing | 2 | |

| | | | |
|----|--------------|------------------|---|
| 38 | EFAGF140.105 | Cover | 1 |
| 39 | GB97.1-85 | Plain washer 14 | 4 |
| 40 | GB93-87 | Spring washer 14 | 4 |
| 41 | GB5783-86 | Bolt M14X45 | 4 |

5.3 Blade Axle Subassembly

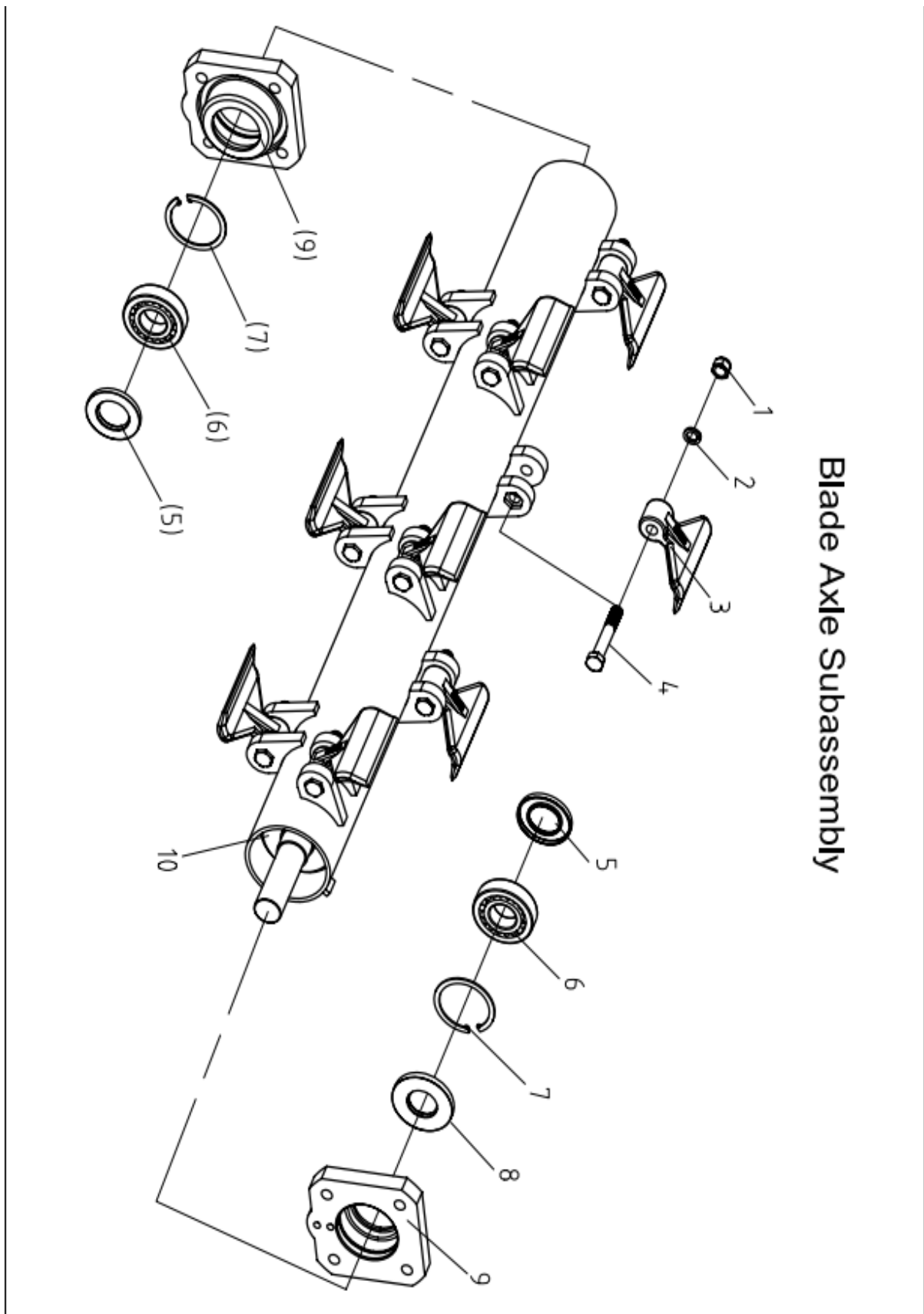

Blade Axle Subassembly

Blade Axle Subassembly

| NO. | Part NO. | Name & Specifications | Quantity | Remark |
|-----|-------------|-----------------------|----------|--------|
| 1 | GB6184-86 | Locking nut M16 | 12 | |
| 2 | GB93-87 | Spring washer 16 | 12 | |
| 3 | EFAG140.103 | Hoe | 12 | |
| 4 | GB5782-86 | Bolt M12x80 | 12 | |
| 5 | GB13871-94 | Oil seal 45X80X10 | 2 | |
| 6 | GB/T281-94 | Bearing 1308 | 2 | |
| 7 | GB893.1-86 | Circlip 90 | 2 | |
| 8 | GB13871-94 | Oil seal 40X90X10 | 1 | |
| 9 | EFAG140.102 | Bearing seat | 2 | |
| 10 | EFAG140.019 | Blade axle weldment | 1 | |

The information contained in this operations manual is a general introduction only. The information contained herein may be modified at any time, for any reason. Modification may affect the details or specifications of the product described in this manual. Therefore, users – dealers must include the manufacturing date and serial number when placing an order for spare parts and components. Thanks.