



# LandMax

Suppliers Of Quality Agricultural Machinery

**21 Plummers Point Road, Tauranga**



## **Flail Mower**

**EFGC / EFGCH**

# **Operator's Manual**

- 1. SAFETY PRECAUTIONS ..... 3**
  - 1.1 Safety First..... 3
  - 1.2 General Safety ..... 3
  - 1.3 Operating Safety..... 4
  - 1.4 Storage Safety ..... 4
  - 1.5 Maintenance Safety ..... 5
  - 1.6 Safety & Model Decals ..... 7
- 2. PRODUCT SPECIFICATIONS ..... 9**
  - 2.1 Implement Specifications..... 9
  - 2.2 Identification of the implement ..... 10
- 3. OPERATION ..... 11**
  - 3.1 Checking Before Operating ..... 11
  - 3.2 Adjustments ..... 11
  - 3.3 Drive Belt Adjustment ..... 12
  - 3.4 Starting Up ..... 13
  - 3.5 Hydraulic Connection ..... 14
  - 3.6 Greasing and Lubrication ..... 14
- 4. SERVICE AND MAINTENANCE ..... 15**
  - 4.1 Service ..... 15
  - 4.2 Maintenance ..... 15
- 5. STORAGE ..... 18**
  - 5.1 Operation After Storage ..... 18
- 6. TROUBLESHOOTING ..... 19**
- 7. PARTS LISTS ..... 20**

---

# 1. SAFETY PRECAUTIONS

---



## WARNING

Before operating the Flail mower, read the following safety instructions. Failure to comply with these warnings may result in serious injury or death.

---

## 1.1 Safety First

YOU are responsible for the SAFE operation and maintenance of your Flail mower. YOU must ensure that you and anyone else who is going to operate, maintain or work around the Flail mower is familiar with the operating and maintenance procedures and related SAFETY information contained in this manual. This manual will take you step-by-step through your working day and alert you to all good safety practices that should be adhered to while operating the Flail mower.

Remember, YOU are the key to safety. Good safety practices not only protect you but also the people around you. Make these practices a working part of your safety program. Be certain that EVERYONE operating this equipment is familiar with the recommended operating and maintenance procedures and follows all the safety precautions. Most accidents can be prevented. Do not risk injury or death by ignoring good safety practices.

- Flail mower owners must give operating instructions to operators or employees before allowing them to operate the machine.
- The most important safety feature on this equipment is a SAFE operator. It is the operator's responsibility to read and understand ALL Safety and Operating instructions in the manual and to follow these. All accidents can be avoided.
- A person who has not read and understood all operating and safety instructions is not qualified to operate the machine. An untrained operator jeopardies himself and bystanders to possible serious injury or death.
- Do not modify the equipment in any way. Unauthorized modification may weaken the function and/or safety and could affect the life of the equipment.
- Think SAFETY! Work SAFELY!

## 1.2 General Safety

1. Read the operator's Manual and all safety signs carefully before operating, maintaining, adjusting or removing the Flail mower.
2. Do not allow passengers to ride on the Flail mower
3. Operate only at safe distance from bystanders. Clear the area of people, especially small children, before starting.
4. Stop PTO before dismounting tractor.
5. Keep feet and hands from under Flail mower at all times.
6. Keep all shields in place. If shield removal becomes necessary for repairs, replace the shield prior to use.
7. Do not stay between the tractor and the Flail mower.
8. Do not approach the Flail mower until all motion has stopped.
9. All rotary blades have the ability to discharge objects at high speeds, which could result in serious injury to bystanders or passers-by, use with extreme caution.
10. Place all controls in neutral, stop tractor engine, set park brake, remove ignition key and wait for all moving parts to stop before servicing, adjusting, repairing, attaching or removing.

- 
11. Review safety related items annually with all personnel who will operate or maintain the Flail mower.
  12. Do not operate machine if you feel unwell or physically unfit, in which case you should stop working.
  13. This machine was designed with safety very much in mind. However, there is no real substitute for caution and attention in preventing accidents. Once an accident has happened, it is too late to think about what you should have done.
  14. Use a tractor equipped with a Roll Over Protective Structure (ROPS). Always wear your seat belt. Serious injury or even death could result from falling off the tractor – particularly during a turnover when the operator could be pinned under the ROPS or the tractor.
  15. Never exceed the limits of a piece of machinery. If its ability to do a job, or to do so safely, is in question – DON'T TRY IT.
  16. Clear working area of stones, branches or hidden obstacles that might be hooked or snagged, causing injury or damage.

## 1.3 Operating Safety

1. Read and understand the Operator's Manual and all safety signs before operating, servicing, adjusting, repairing or removing.
2. Do not allow riders.
3. Install and secure all guards and shields before starting or operating.
4. Keep hands, feet, hair and clothing away from moving parts.
5. Place all controls in neutral, stop tractor engine, set park brake, remove ignition key and wait for all moving parts to stop before servicing, adjusting, repairing, attaching or removing.
6. Place all tractor and machine controls in neutral before starting.
7. Never start or operate machine unless sitting on tractor seat.
8. Clear the area of bystanders, especially small children, before starting.
9. Stay away from PTO shaft and machine when engaging PTO. Keep others away.
10. Use warning lights on tractor when transporting.
11. Do not put hands or feet under machine while tractor engine or machine is running.
12. Do not operate Flail mower in the raised position.
13. Objects can be thrown out from under machine with sufficient force to severely injure people. Stay away from machine when it is running. Keep others away.
14. Always know what you are cutting. Never operate the Flail mower in an area that has hidden obstacles. Remove sticks, stones, wire or other objects from working area before starting.
15. Review safety instructions with all operators annually.

## 1.4 Storage Safety

1. Store the machine in an area away from human activity.
2. Do not permit children to play on or around the stored machine.
3. Store the machine in a dry, level area.
4. Clean grease and oil as required and protect it from the elements.

---

## 1.5 Maintenance Safety

1. Good maintenance is your responsibility. Poor maintenance is an invitation to trouble.
2. Follow good shop practices.
3. Keep service area clean and dry.
4. Be sure electrical outlets and tools are properly grounded.
5. Use adequate light for the job at hand.
6. Make sure there is plenty of ventilation. Never operate the engine of the tractor in a closed building. The exhaust fumes may cause asphyxiation.
7. Before working on this machine, shut off the engine, set the brakes, and remove the ignition key.
8. Never work under equipment unless it is secured by a mechanical stand.
9. Use personal protection devices such as eye, hand and hearing protectors, when performing any service or maintenance work. Use heavy gloves when handling blades.
10. Only use genuine parts for service and maintenance.
11. A fire extinguisher and first aid kit should be kept readily accessible while performing maintenance on this equipment.
12. Periodically tighten all bolts, nuts and screws and check that all pins are properly installed to ensure unit is in a safe condition.
13. When completing a maintenance or service function, make sure all safety shields and devices are installed before placing machine in service.

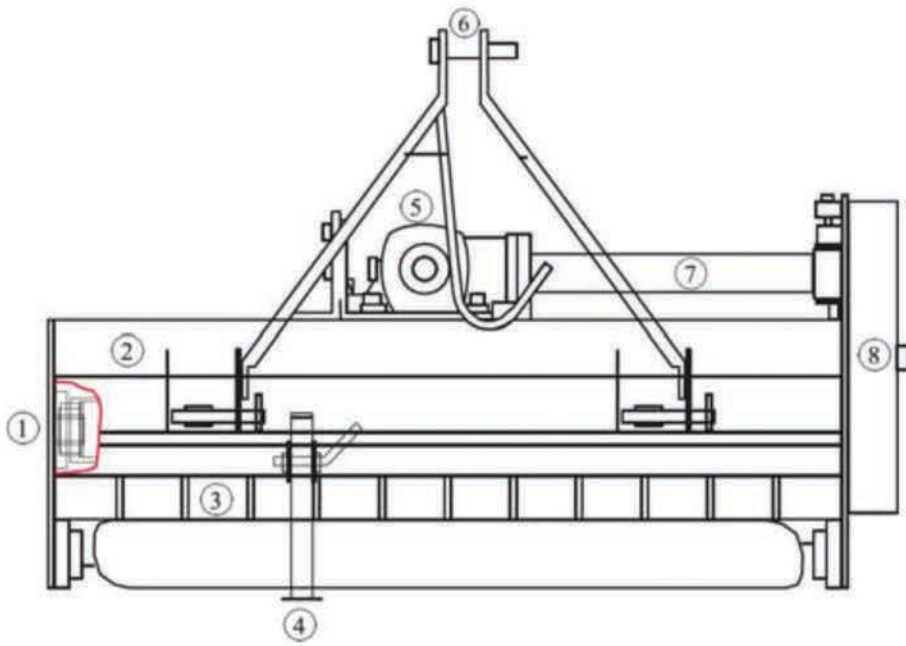

|    |                     |
|----|---------------------|
| 1. | Blade axle          |
| 2. | Blade axle cover    |
| 3. | Combined fender     |
| 4. | Stand               |
| 5. | Gear box            |
| 6. | Top Link Bracket    |
| 7. | Transmission shaft  |
| 8. | Belt & Pulley Cover |

### PTO Shaft

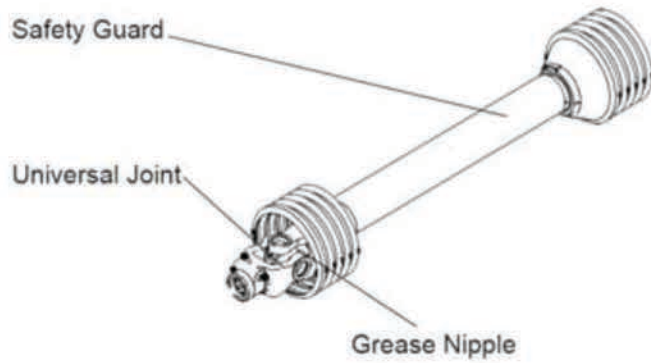

---

## 1.6 Safety & Model Decals

The position of safety decals is shown in the illustrations below. Good safety requires that you familiarize yourself with the various safety signs, and increase your SAFETY AWARENESS.

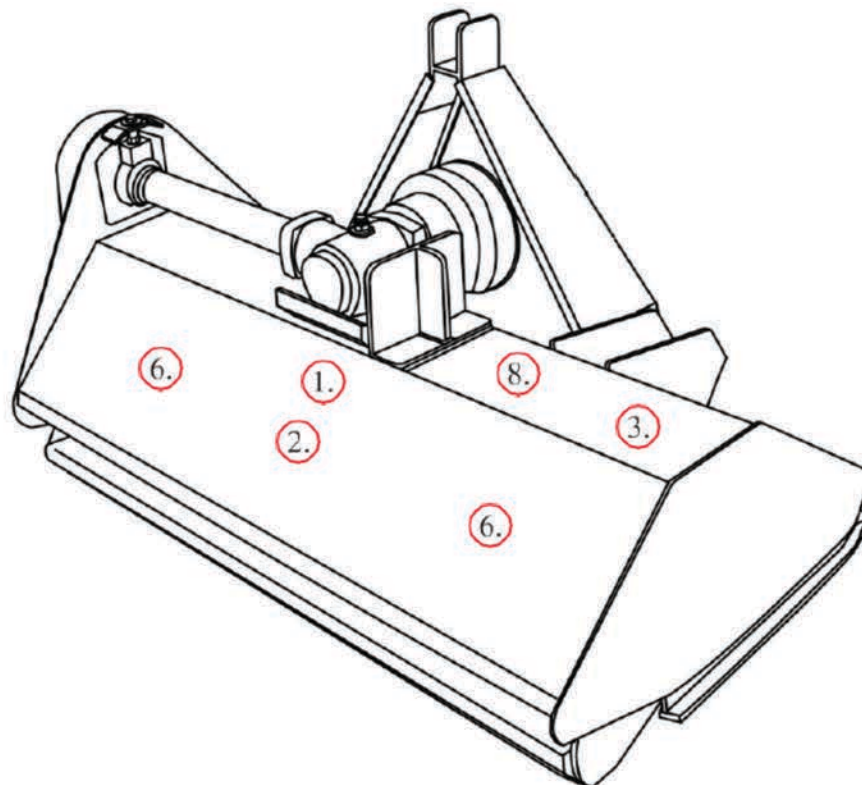
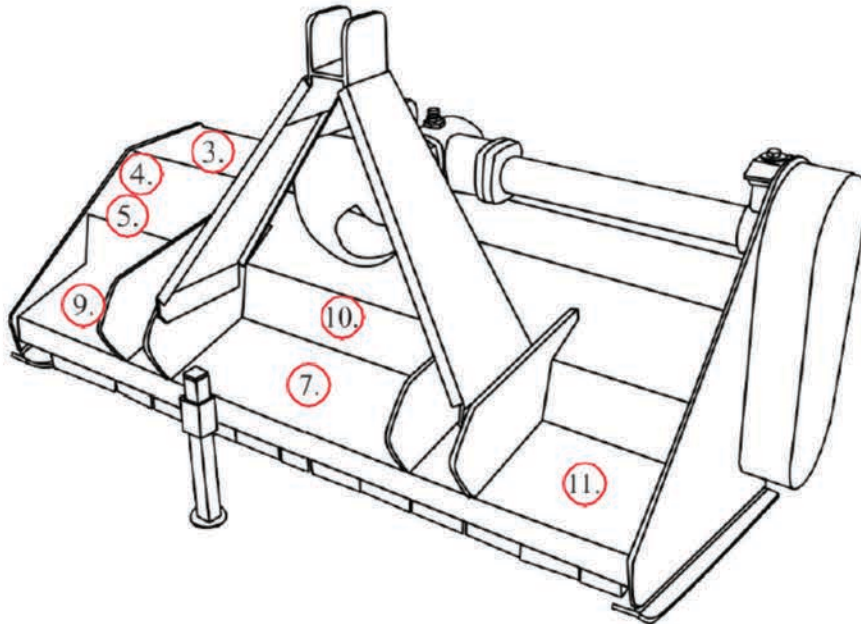





---

## 2. PRODUCT SPECIFICATIONS

### 2.1 Implement Specifications

| Model         | EFGC105 | EFGC125 | EFGC145 | EFGC155 | EFGC165 | EFGC175 |
|---------------|---------|---------|---------|---------|---------|---------|
| Cutting Width | 1050mm  | 1250mm  | 1450mm  | 1550mm  | 1650mm  | 1750mm  |
| Rotor Speed   | 540rpm  | 540rpm  | 540rpm  | 540rpm  | 540rpm  | 540rpm  |
| Hammer Blade  | 16      | 20      | 24      | 24      | 28      | 28      |
| Y Blade       | 32      | 40      | 48      | 48      | 56      | 56      |
| Weight        | 210kg   | 230kg   | 250kg   | 260kg   | 270kg   | 280kg   |
| Tractor HP    | 20-30hp | 25-40hp | 35-45hp | 40-55hp | 40-55hp | 45-65hp |
| NO OF HAMMER  | 16      | 20      | 24      | 24      | 28      | 28      |
| NO OF BELTS   | 2       | 2       | 3       | 3       | 3       | 4       |

| Model         | EFGCH105 | EFGCH125 | EFGCH145 | EFGCH155 | EFGCH165 | EFGCH175 |
|---------------|----------|----------|----------|----------|----------|----------|
| Cutting Width | 1050mm   | 1250mm   | 1450mm   | 1550mm   | 1650mm   | 1750mm   |
| Rotor Speed   | 540rpm   | 540rpm   | 540rpm   | 540rpm   | 540rpm   | 540rpm   |
| Hammer Blade  | 16       | 20       | 24       | 24       | 28       | 28       |
| Y Blade       | 32       | 40       | 48       | 48       | 56       | 56       |
| Weight        | 196kg    | 225kg    | 255kg    | 270kg    | 285kg    | 300kg    |
| Tractor HP    | 20-30hp  | 25-40hp  | 35-45hp  | 40-55hp  | 40-55hp  | 45-65hp  |
| Side-shift    | 350mm    | 350mm    | 350mm    | 350mm    | 350mm    | 350mm    |

#### USES

- Perfect for use after storms when debris is scattered throughout areas usually maintained with normal mowers
- Multi-purpose machines for mulching foliage and sticks
- Ideal for thick grass, sticks, undergrowth and light vine mulching
- Vegetable and pasture topping
- Roadside maintenance.

#### FEATURES

- Cutting height controlled by adjustable skids
- High strength mulching blades
- Belt driven
- Safety flaps to prevent debris being thrown
- Extra strong and designed with safety in mind
- Support leg for storage
- Solid hitch
- FC-120/160 models include hydraulic flail catcher.

---

## 2.2 Identification of the implement

An Identification plate is affixed to the frame of each implement. It contains the “CE” Certification brand and information about: the Manufacturer, Type, Serial Number, Weight and Year of Manufacture.

### CE Identification Plate

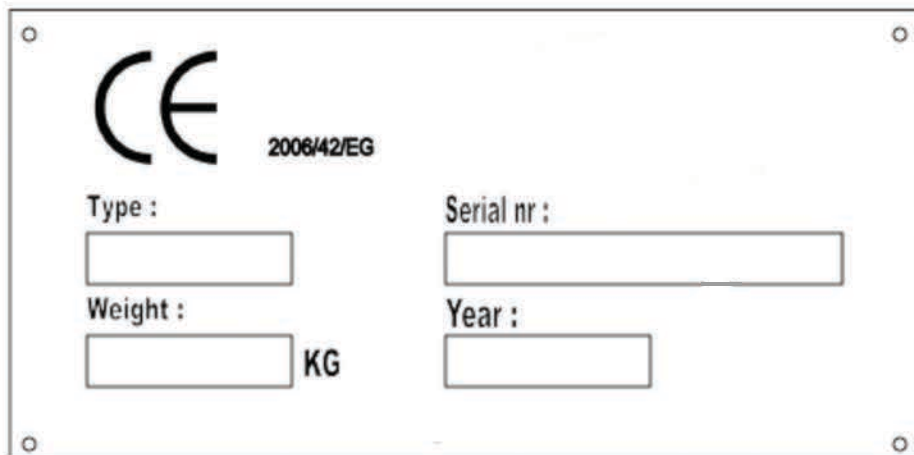

The diagram shows a rectangular identification plate with four corner mounting holes. In the top left corner, there is a large CE mark and the text "2008/42/EG". Below this, the plate is divided into four input fields:

|                         |                      |
|-------------------------|----------------------|
| Type :                  | Serial nr :          |
| <input type="text"/>    | <input type="text"/> |
| Weight :                | Year :               |
| <input type="text"/> KG | <input type="text"/> |

## 3. OPERATION

### 3.1 Checking Before Operating

Before operating the machine, the following areas should be checked off:

1. Before starting up the machine, check and Lubricate all grease points, on the machine and drive shaft.
2. Use only an agricultural tractor with horsepower within limits of the implement.
3. Check that the machine is properly attached to the tractor. Be sure retainers are used on the mounting pins.
4. Be sure extra weights are mounted on the front of the tractor, if required.
5. Check the oil level in the gearbox. Add as required.
6. Check that the tractor PTO shaft turns freely and that the machine driving shaft can telescope easily.
7. Check the blades. Be sure they are not damaged or broken and swing freely in their mount. Repair or replace as required.
8. Check and tighten the blade bolts.
9. Check for entangled material in all rotating parts. Remove this material.
10. Install and secure all guards, doors and covers before starting.
11. Before installing the PTO. ensure the engine is stopped and the PTO shaft is in safe working order.
12. All other people shall leave the area before connecting the driving power from the tractor. Keep the output of the tractor at 540 RPM.
13. Before cleaning, repairing and lubricating the machine, stop the motor and take the key away with you.
14. When the PTO shaft is not connected with the tractor, support it through the frame to protect it from lying in the dirt.
15. Don't approach the machine when it is operating.

### 3.2 Adjustments

#### ADJUSTING THE HEIGHT

To get the most out of your flail mower, it should be set within the recommended height.

To save fuel and power, and reduce wear and tear, the cutting height must be regulated correctly.

When adjusting the working height, loosen screw (1), remove screw (2) on both sides; The roller height (see drawing) can be adjusted by aligning the selected hole in the roller support bracket at position 2. The lowest hole is the highest working height; put the screw (2) into the selected hole; tighten screw (1) and screw (2).

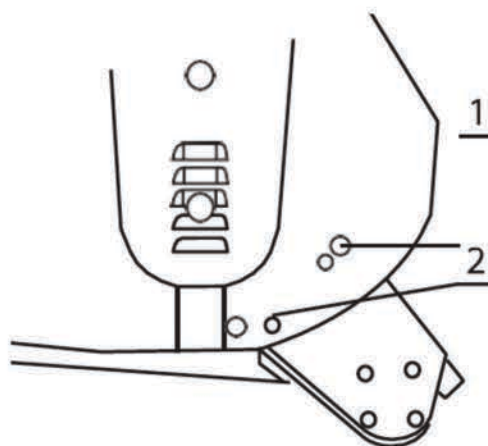

#### FLAIL MOWER ADJUSTMENT

1. On a flat piece of ground, attach the Flail mower to the tractor using the three point linkage.
2. Use a solid adjustable top link.
3. Lower the three point linkage to its lowest position.
4. With the roller at the rear in contact with the ground, adjust the length of the top link so that the lower edge at the side of the flail mower is parallel with the ground.
5. Rotate the blade drum by hand so that a row of blades hang vertically towards the ground.

6. Measure the clearance between the bottom of the extended blades and the ground.
  - Minimum 50mm
  - Note: In rough or lumpy paddocks, the clearance needs to be increased to ensure that the blades don't impact the ground in operation.
7. Adjust the roller height to increase or decrease the blade clearance as required.
8. Go through steps 4 to 7 until the required clearance is achieved.

When the Flail mower has been set up with the required tolerances: operate the Flail mower with tractor in low range and the PTO delivering 540 RPM.

### 3.3 Drive Belt Adjustment

1. Loosen the Screw A and B that locks the support shaft and loosen the counter nut C. Loosen the screws that lock the gear box on the mounting plate D.
2. Adjust the drive belt tension. The correct belt tension is achieved when the belt can be deflected by the belt thickness about 10mm at the center point between the pulleys.
3. Align the gearbox so the drive shaft is parallel with the body.
4. Use a straight edge to make sure the belt pulleys are in line and running true. If misaligned, call your dealer or service agent for technical support.
5. Fit the safety covers and tighten the mounting bolts before operation.

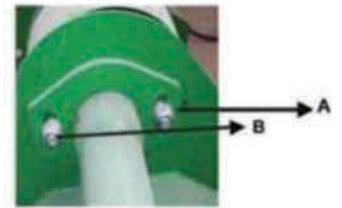

Approx 10mm deflection



Align with a straight edge

## 3.4 Starting Up

Before starting the machine, check and adjust the following items:

- Drive belt tension.
- Gearbox oil level.
- Grease nipples on bearings and PTO shaft.
- All bolts, nuts and screws.

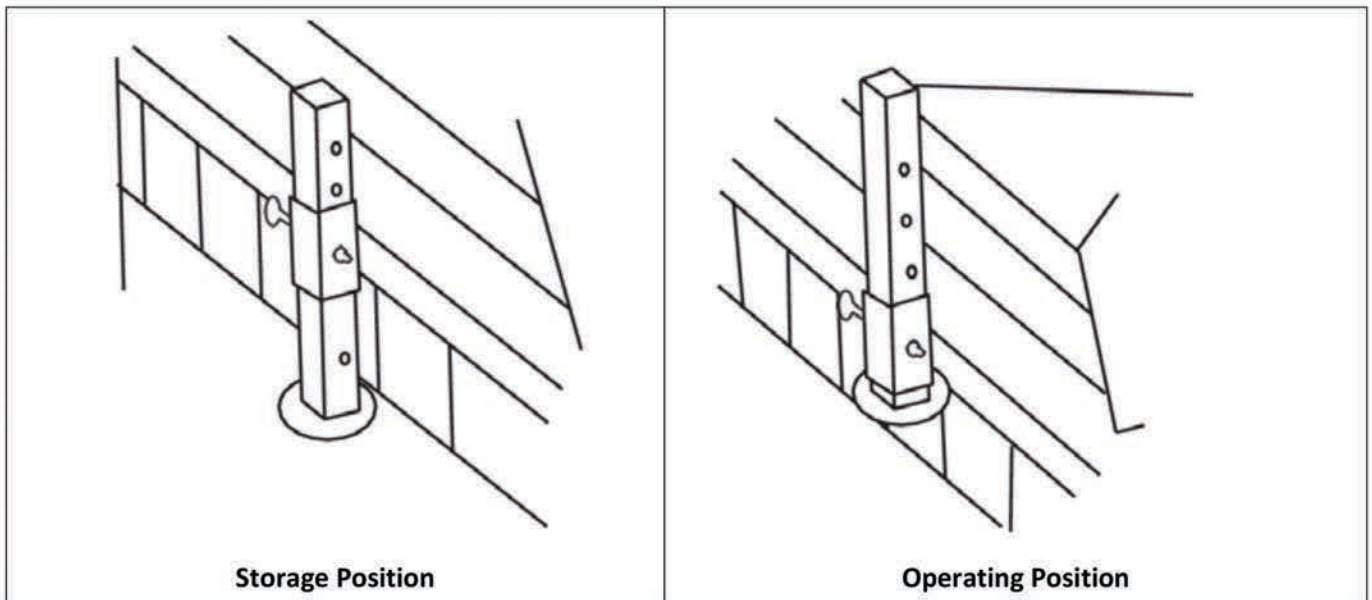

In order to keep the machine stable, lower the adjustment stand when the machine is stopped (see above drawing). Follow all safety precautions detailed in this manual.

The machine is equipped with a standard category one, three point linkage.

Back the tractor into position in front of the flail mower. Lower the tractor hydraulic lift arms. Turn the tractor off. Maneuver the implement by hand and attach the lower link arms to the lower link pin. Ensure they are secured with lynch pin. Attach the top link to the top link bracket. Adjust the lower link sway chains to allow minimal lateral movement. Attach the PTO shaft to the tractor PTO ensuring it has been cut to the required length.

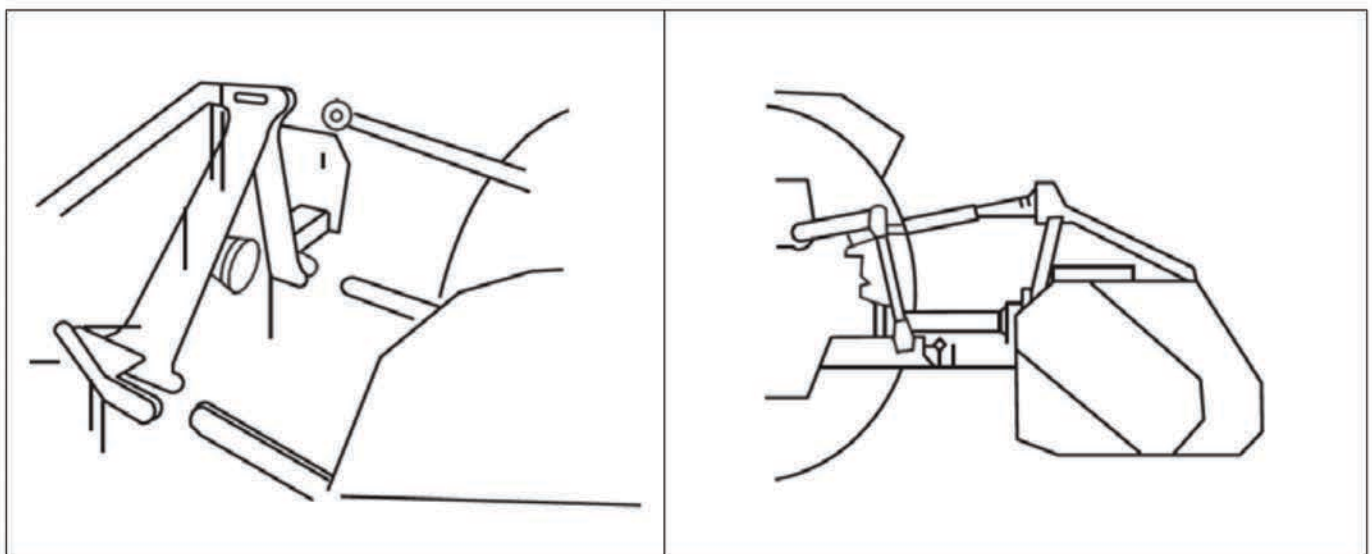

---

## 3.5 Hydraulic Connection

- Switch the engine off, set the handbrake and remove the ignition key. Push the hydraulic lever to release pressure at the remotes. Connect the implement's hydraulic hoses to the remotes using the quick couplers, having checked the quick couplers are clean and in good condition.
- Start the engine and activate the hydraulics to check the connection. Check there are no oil leaks at the connection or the implement.
- Before disconnecting, stop the engine and move the remotes lever back and forth to release the hydraulic oil pressure as previously mentioned.

## 3.6 Greasing and Lubrication

### EACH 4 HOURS OF WORK

- Check and tighten nuts and bolts.
- Grease with lithium based grease when it is indicated by the symbol GREASE.

### AFTER 50 HR OF WORK

Check and fill the gearbox to the required level, using oil type SAE 90 EP API GL4.

### EACH 100 HR OF WORK

Check the gearbox oil level. Replace as required.



---

## 4. SERVICE AND MAINTENANCE

### 4.1 Service

#### FLUIDS AND LUBRICANTS

- Grease: Use multi-purpose lithium based grease.
- Gear Box Oil: Use SAE 90 Gear oil.
- Storing Lubricants: Your machine can operate at top efficiency only if clean lubricants are used. Use clean containers to handle all lubricants. Store them in an area protected from dust, moisture and other contaminants.

#### GREASING

1. Use a hand-held grease gun for all greasing.
2. Wipe grease nipple with a clean cloth before greasing, to avoid injecting dirt and grit.
3. Replace broken nipples immediately.
4. If nipples will not take grease, remove and clean thoroughly. Also clean lubricant passageway. Replace nipple if necessary.

### 4.2 Maintenance

The period recommended is based on normal operating conditions. Severe or unusual conditions may require more frequent maintenance.

#### 8 HOURS OR DAILY MAINTENANCE

1. Check all nuts and bolts, tighten as required.
2. Check the blade and blade bolts every day and replace the damaged parts. Don't install damaged, worn and unbalanced blade. Replace sleeves as they become worn.



#### NOTE

The operator should put on gloves and use suitable tools before changing blade.

---

3. Check the oil in gearbox. Fill up to line if necessary.
4. Pump grease into each grease nipple three to five times.
5. Clean the implement; remove grass and mud.

#### SEASON MAINTENANCE

1. Check the machine as in the terms of daily maintenance.
2. Check the oil in gearbox; replace it if it is contaminated.
3. Check the blade spindles for wear and tear. If worn, disassemble and clean them and replace them if it is necessary, grease as required.

---

## ANNUAL MAINTENANCE

1. Thoroughly clean mud and grass off the machine.
2. Check and clean blade axles. Replace seals and grease as required.
3. Check all blades, replace then if they are wear-out or damaged.
4. Repair or replace the side skirts back to their original size and shape. Replace damaged or broken protective devices.

## GEAR BOX MAINTENANCE

The oil should be drained out and replaced after the first 50 hours of operation. Then the oil should be changed every 250 hours, or at least once a year.

Drain oil from the gearbox thoroughly. Check and clean it. Fill with new gear oil up to the dedicated oil level.

The draining procedure is as follows: remove the draining bolt under the gear box, so that the oil drains off. After the oil is drained out, put the plug back and fill with gear oil up to the dedicated oil level.

|                                     | 8hrs/Daily | 50hrs/Weekly | Annually |
|-------------------------------------|------------|--------------|----------|
| Lubricate PTO Shaft                 | x          | x            | x        |
| Lubricate caster wheels             | x          | x            | x        |
| Lubricate blade spindle             | x          | x            | x        |
| Check gear box oil level            |            | x            | x        |
| Clean machine                       |            |              | x        |
| Lubricate and clean PTO shaft cover |            |              | x        |

## PTO SHAFT MAINTENANCE

The PTO shaft is designed to telescope to allow for dimensional changes as the machine goes through its operating range. A tubular guard encloses the driving components and is designed to turn relative to the driving components. The shaft should telescope easily and the guard turn freely on the shaft at all times. Annual disassembly, cleaning and lubrication is recommended to insure that all components function as intended. To maintain the shaft, follow this procedure:

1. Remove the shaft from the machine.
2. Pull shaft apart.
3. Use a screwdriver to pry the tabs out of the sleeves on each end.
4. Pull the shaft out of the plastic tubular guard.
5. Use a solvent to clean the male and female portions of the telescoping ends.
6. Apply a light coat of grease to each end.
7. Clean the grooves on each end where the tabs are located. Clean each tab also.
8. Apply a light coat of grease to each groove.
9. Insert the shaft into its respective guard and align the slots with the groove.
10. Insert the tabs through the slots and seat in the groove.
11. Check that each guard turns freely on the shaft.
12. Assemble the shaft.
13. Check that the shaft telescopes easily.
14. Replace any components that are damaged or worn.
15. Install the shaft on the machine.



---

## GEAR BOX MAINTENANCE

The gearbox used on the Flail mower will give many years of trouble-free service with minimal maintenance requirements. Maintain the gearbox by following this procedure:

### Oil Level

- Remove the level plug from the rear or side of the gearbox.
- Add oil through the filler plug located on top of gearbox until oil comes out of the level plug.
- Add through the level plug if required.
- If gearbox has a dipstick on filler plug, then fill to indicator mark.



### NOTE

Check the oil level only when the unit is cold and the machine is on the level.

---

---

## 5. STORAGE

- Clean the machine inside and out so as to avoid corrosion.
- Don't spray water on the rolling bearing if you clean the machine with high pressure sprayer.
- Check and clean the universal joint, driving belt press roller, or replace them if they are not in good condition.
- Spread oil on all parts required.
- Recoat the parts rubbed and damaged for anti-corrosion.
- Store the machine in a dry, level area.

### 5.1 Operation After Storage

Before the machine is started up, check the following items regularly:

- Check oil level and add if required.
- Check and tighten all screws and nuts.
- Check the blade condition. Replace as required.
- Check the air hole on the gearbox. If it is blocked, clean or open the hole with compressed air.
- Don't spread oil or grease on the driving belts. If there is oil or grease on the belts, wipe the belts, to avoid slippage and premature wear.
- Check all moving parts and replace them if necessary.
- Check the protective covers are complete and operate correctly.

## 6. TROUBLESHOOTING

| FAILURE                            | CAUSE  | SOLUTION                                  | LEVEL OF DANGER   |
|------------------------------------|--|---|---|
| Excessive vibration of the machine | Broken flails                                    | Replace broken flails                     | Flails can be replaced by a competent operator. In the other cases, replacement must be done by specialised staff.        |
|                                    | Broken rotor support                             | Replace rotor support with original parts |   |
|                                    | Broken driving support shaft                     | Replace shaft support with original parts |   |
|                                    | The worst: bent rotor                            | Replace rotor with original parts         |   |
| The grass is not cut               | Broken flails                                    | Replace flails                            | For replacement of flails, adjustment or replacement belts and fixing lock joints, see paragraph relating to maintenance. |
|                                    | Belt slipping                                    | Adjust belt tension                       |   |
|                                    | Broken belts                                     | Replace belts                             |   |
|                                    | Pulleys slipping on shafts                       | Fix pulley lock joints                    |   |
|                                    | Broken gear box                                  | Repairing or replacement of gear box      |   |
| Clogging of hammers/knives         | Rotor speed is too low                           | Increase rotor speed                      |   |
| Excessive wear of hammers/knives   | Rotor speed is too high                          | Decrease rotor speed                      |   |
| Flail mower vibrates during works  | Foreign matter stuck in between blades           | Remove foreign matter                     | Secure flail mower on a mechanical stand before maintaining blades or rotor.  |
|                                    | Hammers/knives broken                            | Replace hammer/knives                     |   |
|                                    | Bolts of the rotor shaft support have come loose | Lock bolts                                |   |

# 7. PARTS LISTS

## EFGCH Flail Mower Assembly

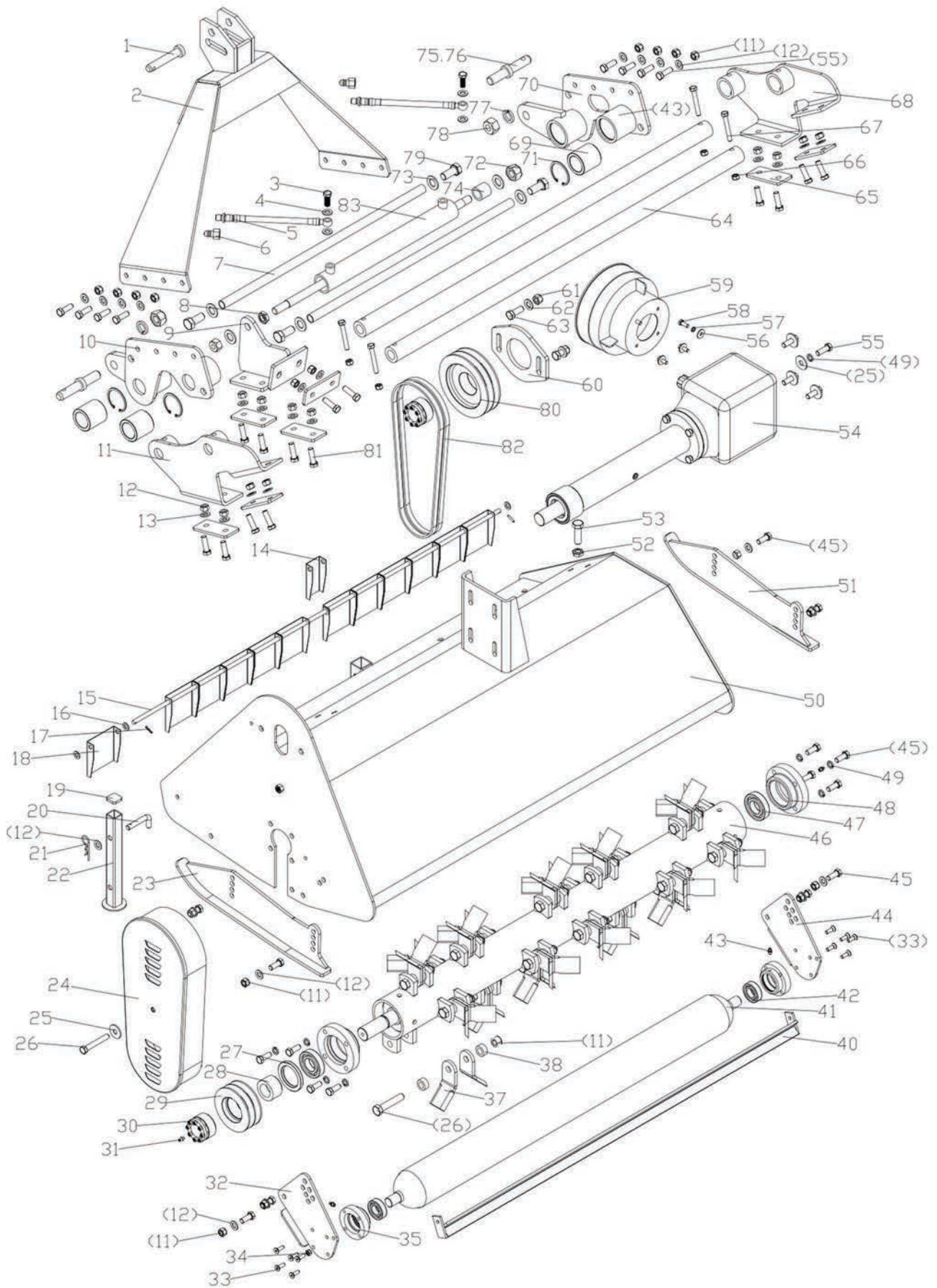

## EFGCH Flail Mower Parts List

| REF | PART NUMBER        | DESCRIPTION                  | QTY           |
|-----|--------------------|------------------------------|---------------|
| 1   | EFGC125.123        | Pin shaft                    | 1             |
| 2   | EFGCH125.017       | Hanging weldment             | 1             |
| 3   | GB3451/M12X1.25X30 | Bolt M12X1.25X30             | 2             |
| 4   | GB3451-86/12       | Washer 12                    | 4             |
| 5   | EFGCH125.012       | Oil pipe                     | 2             |
| 6   | EFGCH125.013       | Quick connector R1/2"        | 2             |
| 7   | EFGCH125.106       | Supporting tube              | 2             |
| 8   | GB6173-86/M18X1.5  | Nut M18x1.5                  | 1             |
| 9   | EFGCH125.014       | Cylinder seat                | 1             |
| 10  | EFGCH125.016       | Slippage bracket(R)          | 1             |
| 11  | EFGCH125.015       | Connecting bracket(R)        | 1             |
| 12  | GB6184-86/M12      | Locking nut M12              | 50 (EFGCH125) |
|     |                    |                              | 46 (EFGCH105) |
|     |                    |                              | 54 (EFGCH145) |
|     |                    |                              | 54 (EFGCH155) |
|     |                    |                              | 58 (EFGCH165) |
|     |                    |                              | 58 (EFGCH175) |
| 13  | GB97.1-85/12       | Plain washer 12              | 53            |
| 14  | EFGC125.114        | Fender                       | 1             |
| 15  | EFGC125.104        | Shaft for fender             | 1             |
| 16  | GB97.1-85/10       | Plain washer 10              | 17 (EFGCH125) |
|     |                    |                              | 15 (EFGCH105) |
|     |                    |                              | 19 (EFGCH145) |
|     |                    |                              | 20 (EFGCH155) |
|     |                    |                              | 21 (EFGCH165) |
|     |                    |                              | 22 (EFGCH175) |
| 17  | GB879-86/4X22      | Elastic cylindrical pin 4x22 | 2             |
| 18  | EFGC125.113        | Fender                       | 12 (EFGCH125) |
|     |                    |                              | 10 (EFGCH105) |
|     |                    |                              | 14 (EFGCH145) |
|     |                    |                              | 15 (EFGCH155) |
|     |                    |                              | 16 (EFGCH165) |
|     |                    |                              | 17 (EFGCH175) |
| 19  | EFGC125.112        | Cover                        | 1             |
| 20  | 1G135.00.107       | Bent pin                     | 1             |
| 21  | EFGC125.110        | R pin                        | 1             |
| 22  | EFGC125.111        | Supporting frame             | 1             |

|    |                       |                           |  |               |
|----|-----------------------|---------------------------|--|---------------|
| 23 | EFGC125. 014          | Base plate (L)            |  | 1             |
| 24 | EFGC125. 012          | Belt cover                |  | 1             |
| 25 | GB96-85/12            | Plain washer 12           |  | 5             |
| 26 | GB5782-86/M12X1. 5X80 | Bolt M12×1.5x80           |  | 21 (EFGCH125) |
|    |                       |                           |  | 17 (EFGCH105) |
|    |                       |                           |  | 25 (EFGCH145) |
|    |                       |                           |  | 25 (EFGCH155) |
|    |                       |                           |  | 29 (EFGCH165) |
|    |                       |                           |  | 29 (EFGCH175) |
| 27 | GB13871-94/55X80X8    | Oil seal FB55X80X8        |  | 1             |
| 28 | EFGC125. 116          | Oil-sealing sleeve        |  | 1             |
| 29 | EFGC125. 117          | Small belt ptlley         |  | 1             |
| 30 | JB/T7934Z3/35X60      | Swellable sleeve          |  | 2             |
| 31 | GB1152-89/M8X1        | Oil cup M8X1              |  | 2             |
| 32 | EFGC125. 105          | Supporting for roller (R) |  | 1             |
| 33 | GB2673-86/M8X25       | Hex.head bolt M8X25       |  | 10            |
| 34 | GB6184-86/M8          | Locking nut M8            |  | 2             |
| 35 | EFGC125. 107          | Bearing                   |  | 2             |
| 37 | EFGC125. 122          | Blade                     |  | 40 (EFGCH125) |
|    |                       |                           |  | 32 (EFGCH105) |
|    |                       |                           |  | 48 (EFGCH145) |
|    |                       |                           |  | 48 (EFGCH155) |
|    |                       |                           |  | 56 (EFGCH165) |
|    |                       |                           |  | 56 (EFGCH175) |
| 38 | EFGC125. 119          | Sleeve                    |  | 40 (EFGCH125) |
|    |                       |                           |  | 32 (EFGCH105) |
|    |                       |                           |  | 48 (EFGCH145) |
|    |                       |                           |  | 48 (EFGCH155) |
|    |                       |                           |  | 56 (EFGCH165) |
|    |                       |                           |  | 56 (EFGCH175) |
| 40 | EFGC125. 016          | Mud shield                |  | 1             |
| 41 | EFGC125. 017          | Roller weldment           |  | 1             |
| 42 | UC205                 | Flange UC205              |  | 2             |
| 43 | GB1152-89/M6          | Oil cup M6                |  | 6             |
| 44 | EFGC125. 106          | Supporting for roller (L) |  | 1             |
| 45 | GB5783-86/M12X30      | Bolt M12x30               |  | 23            |
| 46 | EFGC125. 018          | Blade axle weldment       |  | 1             |
| 47 | UC207-Z               | Flange UC207-Z            |  | 2             |

|    |                      |                       |  |                  |
|----|----------------------|-----------------------|--|------------------|
| 48 | EFGC125.115          | Bearing               |  | 2                |
| 49 | GB93-87/12           | Spring washer 12      |  | 12               |
| 50 | EFGC125.011          | The cover weldment    |  | 1                |
| 51 | EFGC125.015          | Base plate (R)        |  | 1                |
| 52 | GB6173-86/M16x1.5    | Nut M16x1.5           |  | 1                |
| 53 | GB5786-86/M16X1.5X50 | Bolt M16X1.5X50       |  | 1                |
| 54 | EFGC125.019          | Gearbox assembly      |  | 1                |
| 55 | GB5783-86/M12X35     | Bolt M12x35           |  | 12               |
| 56 | GB96-85/8            | Plain washer 8        |  | 4                |
| 57 | GB93-87/8            | Spring washer 8       |  | 4                |
| 58 | GB5783-86/M8X20      | Bolt M8x20            |  | 4                |
| 59 | FM150.120            | Guard shade           |  | 1                |
| 60 | EFGC125.120          | Tension plate         |  | 1                |
| 61 | GB6184-86/M14        | Locking nut M14       |  | 2                |
| 62 | GB97.1-85/14         | Plain washer 14       |  | 2                |
| 63 | GB5783-86/M14X35     | Bolt M14x35           |  | 2                |
| 64 | EFGCH125.108         | Guide rail            |  | 2                |
| 65 | EFGC125.103          | Splint                |  | 7                |
| 66 | GB6184-86/M10        | Locking nut M10       |  | 4                |
| 67 | GB5782-86/M10X70     | Bolt M10x70           |  | 4                |
| 68 | EFGCH125.019         | Connecting bracket(L) |  | 1                |
| 69 | EFGCH125.107         | Nylon bush            |  | 4                |
| 70 | EFGCH125.018         | Slippage bracket(L)   |  | 1                |
| 71 | GB893.1-86/60        | Circlip 60            |  | 4                |
| 72 | GB6184-86/M18X1.5    | Locking nut M18X1.5   |  | 2                |
| 73 | GB97.1-85/18         | Plain washer 18       |  | 6                |
| 74 | EFGCH125.101         | Sleeve                |  | 1                |
| 75 | EFGCH125.102         | Lockpin               |  | 2                |
| 76 | EFGCH125.103         | Pin for lifting       |  | 2                |
| 77 | GB97.1-85/22         | Plain washer 22       |  | 2                |
| 78 | GB6184-86/M22X1.5    | Locking nut M22X1.5   |  | 2                |
| 79 | GB5783-86/M18X40     | Bolt M18X40           |  | 4                |
| 80 | EFGC125.121          | Big belt ptiley       |  | 1                |
| 81 | GB5783-86/M12X40     | Bolt M12x40           |  | 14               |
| 82 | GB/T1154-97/A965     | Strap SPB991          |  | 2 (EFGCH105-125) |
|    |                      |                       |  | 3 (EFGCH145-165) |
|    |                      |                       |  | 4 (EFGCH175)     |
| 83 | EFGCH125.011         | Slippage cylinder     |  | 1                |

## Gearbox Assembly

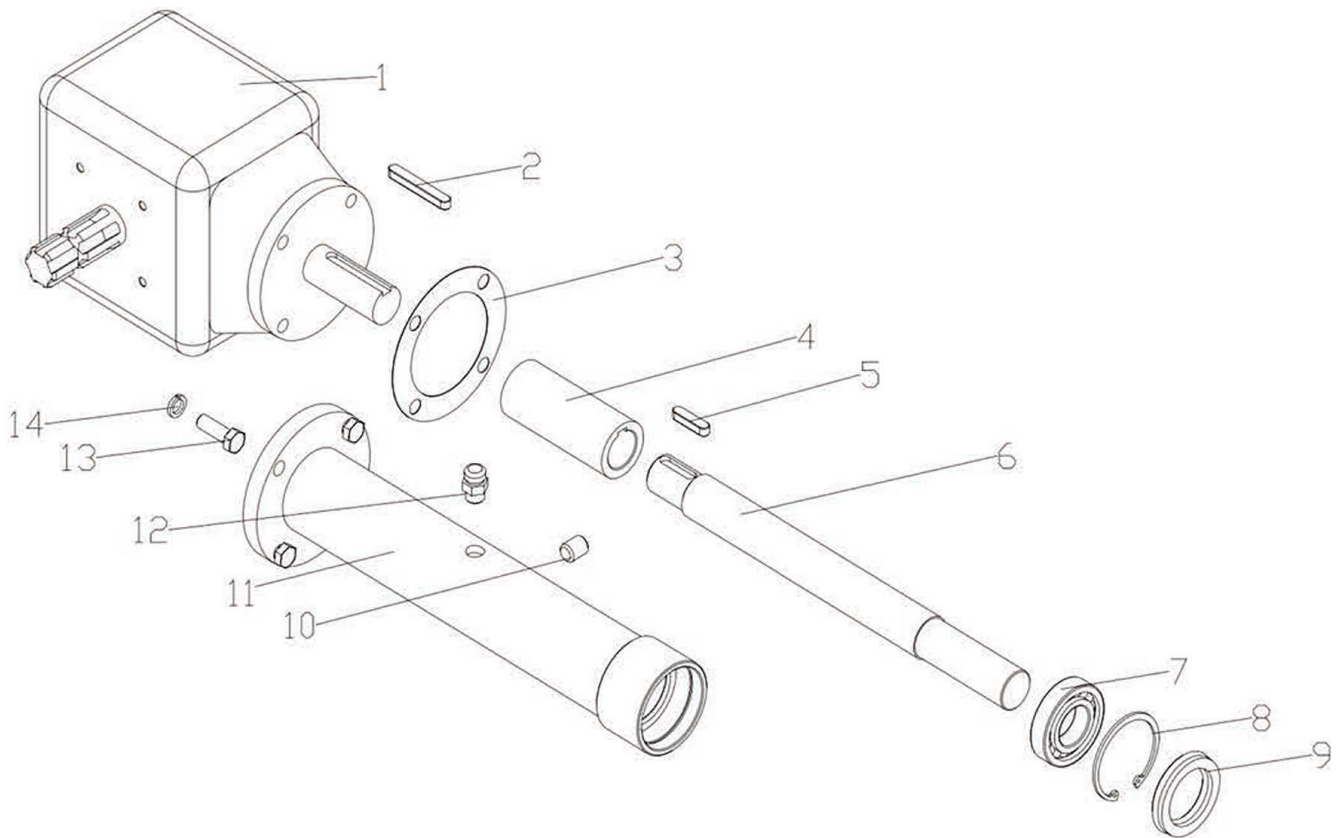

### Gearbox Parts List

| REF | PART NUMBER         | DESCRIPTION                 | QTY |
|-----|---------------------|-----------------------------|-----|
| 1   | XH50. 300Z. 02      | Gearbox assembly            | 1   |
| 2   | GB1096-79/A10X70    | Key A10X70                  | 1   |
| 3   | EFGC125. 166        | Paper gasket                | 1   |
| 4   | EFGC125. 167        | Connected sleeve            | 1   |
| 5   | GB1096-79/A10X40    | Key A10X40                  | 1   |
| 6   | EFGC125. 168        | Shaft                       | 1   |
| 7   | GB/T276-94/6207     | Bearing 6207                | 1   |
| 8   | GB893. 1-86/72      | Circlip 72                  | 1   |
| 9   | GB13871-94/35X72X10 | Oil seal 35x72x10           | 1   |
| 10  | ZBT 32001. 3-87     | Retainer                    | 1   |
| 11  | EFGC125. 020        | Shaft tube weldment         | 1   |
| 12  |                     | Bolt of plug screw M16X1. 5 | 1   |
| 13  | GB5783-86/M12X35    | Bolt M12X35                 | 4   |
| 14  | GB93-87/12          | Spring washer 12            | 12  |