



LandMax

Suppliers Of Quality Agricultural Machinery

21 Plummers Point Road, Tauranga



Ripper Pipelayer

RPL

Operator's Manual

Ripper Pipelayer Owner's Manual

CAUTION

THE FOLLOWING SAFETY PRECAUTIONS SHOULD BE THOROUGHLY UNDERSTOOD BEFORE ATTEMPTING TO BEGIN ASSEMBLING THIS MACHINE

1. Select an area for assembly that clean and free of any debris which might cause persons working on the assembly to trip.
2. Do not lift heavy parts or assemblies. Use crane jack, tackle, fork trucks or other mechanical device.
3. Never put hands, or any part of body, under blocked up assemblies if at all possible.
4. After completing assembly, thoroughly inspect the machine to be sure that all nuts, bolts, hydraulic fittings or any other fastened assemblies have been thoroughly tightened.
5. Before operating equipment—If you have any questions regarding the proper assembly or operations, contact your dealer or the manufacturer.

Important Safety Information!

Working with unfamiliar equipment can lead to careless injuries, Read this manual and the manual for your tractor. before assembly or operating, to acquaint yourself with the machine. It is the Ripper Pipelayer owner's responsibility, if this machine is used by any other person other than yourself, is loaned or rented, to make certain that the operator is instructed in safe and proper use.

The use of this equipment is subjected to certain hazards which can not be protected by mechanical means or product design. All operators of this equipment must read and understand this manual, paying particular attention to safety instructions, prior to using. If there is something you do not understand, ask your supervisor, or your dealer, to explain it to you.

Most accidents occur because of neglect or carelessness. Keep all helpers and bystanders twenty-five (25') from an operating Ripper Pipelayer. Only properly trained people should operate this machine.

Personal protection equipment including safety glasses, safety shoes, and gloves are recommended during assembly, installation, operation, adjustment, maintaining, repairing, removal, or moving the Ripper Pipelayer.

Never place any part of your body where it would be in danger if movement should occur during assembly, installation, operation, maintaining, repairing, removal, or moving the Ripper Pipelayer.

Before you operate the Ripper Pipelayer, check over all pins, bolts and connections to be sure all are securely in place, Replace any damaged or worn parts immediately. Do not allow anyone who is not familiar with the safety rules and operation instruction to use this Ripper Pipelayer.

RP-L Pipe Player Assembly

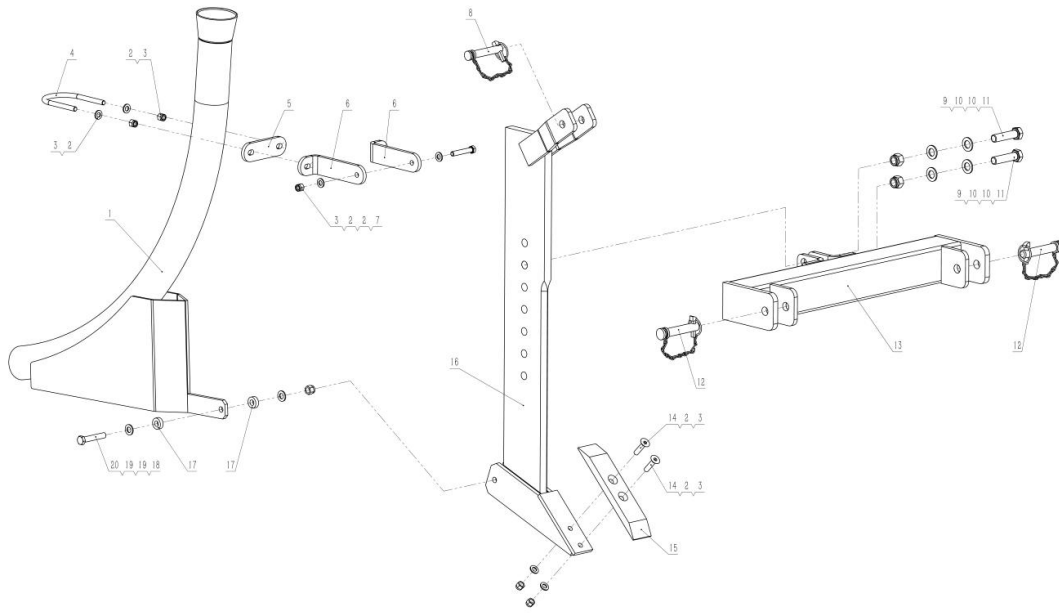

RP-L Ripper Pipelayer Parts List

REF	Part No.	Name & Specification	Quantity
1	RP-L.011	Bend pipe welding parts	1
2	GB/T 97.1-Ø12	Flat pad 12	6
3	GB/T 889.1-M12	Lock nut M12	5
4	RP-L.101	U-bolt	1
5	RP-L.103	Round tube pad	1
6	RP-L.102	Round tube fixing plate	2
7	GB/T 5782-M12×70	Bolt M12×70	1
8	EFGC175.116	upper suspension pin	1
9	GB/T 889.1-M20	Lock nut M20	2
10	GB/T 97.1-Ø20	Flat pad 20	4
11	GB/T 5782-M20×80	Bolt M20×80	2
12	LS-22T-107	Lower suspension pin	2
13	STR-L.012	Suspension rack	1
14	GB/T 70.3-M12×50	Hexagon socket countersunk head screw M12×50	2
15	STR-L.101	Single share plow	1
16	STR-L.011	Single-share trenching machine tool holder (large)	1
17	RP-L.104	Gasket	2
18	GB/T 889.1-M14	Lock nut M14	1
19	GB/T 97.1-Ø14	Flat pad 14	2
20	GB/T 5782-M14×80	Bolt M14×80	1